

Service
Service
Service



Service Manual

TABLE OF CONTENTS

Handling chip components1-1
 Technical specification.....2-1
 Service tools2-1
 Service measurement setup.....2-2
 Connections and controls3-1...3-2

Disassembly diagram4-1
 Pin description of ICs.....4-2...4-10
 Set block diagram5-1
 Set wiring diagram5-2

LED BOARD
 circuit diagram6-1
 layout diagram6-1

POWER BOARD
 circuit diagram7-1
 layout diagram7-1

HEADPHONE BOARD
 circuit diagram7-1
 layout diagram7-1

VCD & TAPE BOARD
 circuit diagram - CD8-1
 circuit diagram - TAPE.....8-2
 circuit diagram - MPEG.....8-3
 layout diagram - component side.....8-4
 layout diagram - SMD side8-5



FRONT BOARD
 circuit diagram9-1
 layout diagram9-2

MAIN BOARD
 circuit diagram - power amplifier.....10-1
 circuit diagram - tuner10-2
 circuit diagram - karaoke10-3
 layout diagram - component side.....10-4
 layout diagram - SMD side10-5

ADJUSTMENT TABLE
 tuner adjustment table11-1
 tape deck adjustment.....11-1

Exploded view (main set).....12-1
 Mechanical partslist13-1
 Electrical partslist.....13-2...13-4

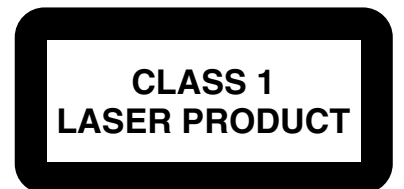

© Copyright 2001 Philips Consumer Electronics B.V. Eindhoven, The Netherlands
 All rights reserved. No part of this publication may be reproduced, stored in a retrieval system or transmitted, in any form or by any means, electronic, mechanical, photocopying, or otherwise without the prior permission of Philips.

Published by SL 0232 Service Audio Printed in The Netherlands Subject to modification

GB 3140 785 32160



PHILIPS

HANDLING CHIP COMPONENTS

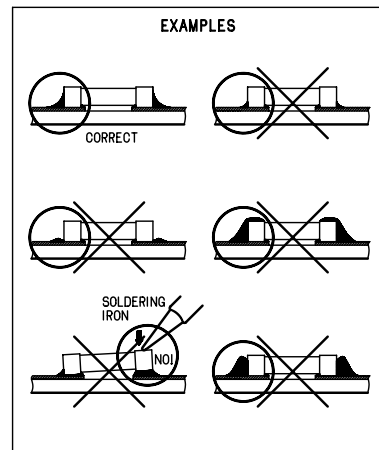
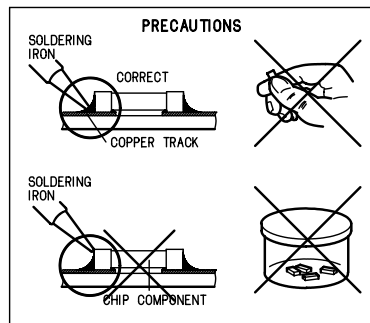
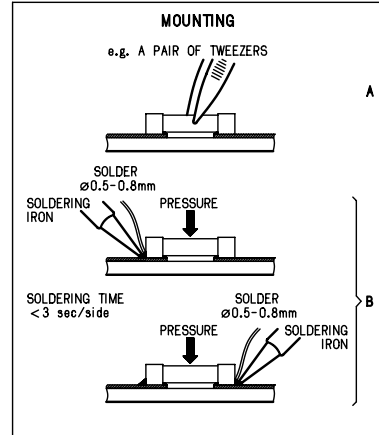
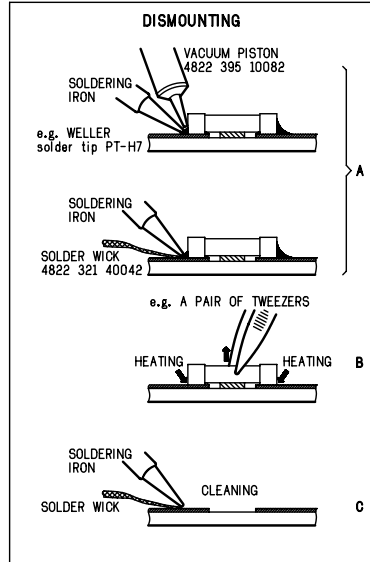
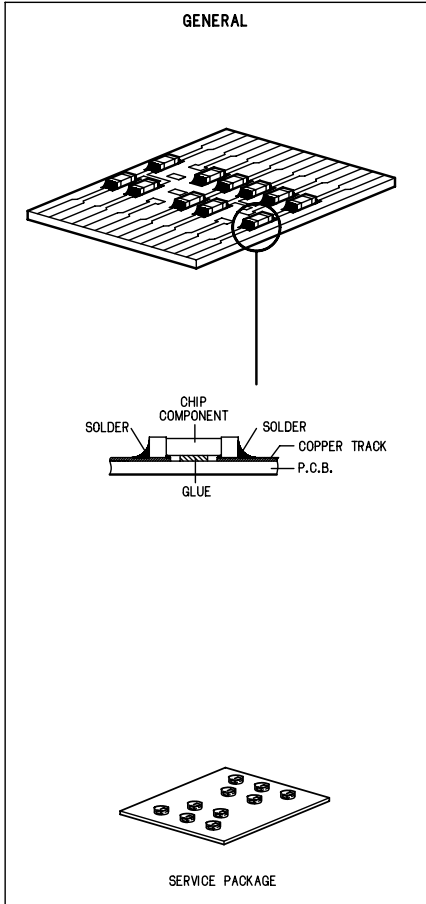

(GB) WARNING

All ICs and many other semiconductors are susceptible to electrostatic discharges (ESD). Careless handling during repair can reduce life drastically. When repairing, make sure that you are connected with the same potential as the mass of the set via a wristband with resistance. Keep components and tools at this potential.

ESD



(NL) WAARSCHUWING

Alle IC's en vele andere halfgeleiders zijn gevoelig voor electrostatische ontladingen (ESD). Onzorgvuldig behandelen tijdens reparatie kan de levensduur drastisch doen verminderen. Zorg ervoor dat u tijdens reparatie via een polsband met weerstand verbonden bent met hetzelfde potentiaal als de massa van het apparaat. Houd componenten en hulpmiddelen ook op ditzelfde potentiaal.

(F) ATTENTION

Tous les IC et beaucoup d'autres semi-conducteurs sont sensibles aux décharges statiques (ESD). Leur longévité pourrait être considérablement écourtée par le fait qu'aucune précaution n'est prise à leur manipulation. Lors de réparations, s'assurer de bien être relié au même potentiel que la masse de l'appareil et enfilez le bracelet sert d'une résistance de sécurité. Veiller à ce que les composants ainsi que les outils que l'on utilise soient également à ce potentiel.

(D) WARNUNG

Alle ICs und viele andere Halbleiter sind empfindlich gegenüber elektrostatischen Entladungen (ESD). Unvorsichtige Behandlung im Reparaturfall kann die Lebensdauer drastisch reduzieren. Sorgen Sie dafür, daß Sie im Reparaturfall über ein Polarmband mit Widerstand mit dem Massepotential des Gerätes verbunden sind. Halten Sie Bauteile und Hilfsmittel ebenfalls auf diesem Potential.

(I) AVVERTIMENTO

Tutti IC e parecchi semi-conduttori sono sensibili alle scariche statiche (ESD). La loro longevità potrebbe essere fortemente ridotta in caso di non osservazione della più grande cautela alla loro manipolazione. Durante le riparazioni occorre quindi essere collegato allo stesso potenziale che quello della massa dell'apparecchio tramite un bracciale a resistenza. Assicurarsi che i componenti e anche gli utensili con quali si lavora siano anche a questo potenziale.

(GB)

Safety regulations require that the set be restored to its original condition and that parts which are identical with those specified be used. Safety components are marked by the symbol ▲

(F)

Les normes de sécurité exigent que l'appareil soit remis à l'état d'origine et que soient utilisées les pièces de rechange identiques à celles spécifiées. Les composants de sécurité sont marqués ▲

SAFETY



(D)

Bei jeder Reparatur sind die geltenden Sicherheitsvorschriften zu beachten. Der Originalzustand des Gerätes darf nicht verändert werden. Für Reparaturen sind Originalersatzteile zu verwenden. Sicherheitsbauteile sind durch das Symbol ▲ markiert.

(NL)

Veiligheidsbepalingen vereisen, dat het apparaat in zijn oorspronkelijke toestand wordt teruggebracht en dat onderdelen, identiek aan de gespecificeerde, worden toegepast. De Veiligheidsonderdelen zijn aangeduid met het symbool ▲

(I)

Le norme di sicurezza estigono che l'apparecchio venga rimesso nelle condizioni originali e che siano utilizzati i pezzi di ricambio identici a quelli specificati. Componenti di sicurezza sono marcati con ▲

(GB) DANGER: Invisible laser radiation when open. AVOID DIRECT EXPOSURE TO BEAM.

(S) Varning!

Osynlig laserstrålning när apparaten är öppnad och spärrar är urkopplad. Betrakta ej strålen.

(DK) Advarsel!

Usynlig laserstrålning ved åbning når sikkerhedsafbrydere er ude af funktion. Undgå udsættelse for stråling.

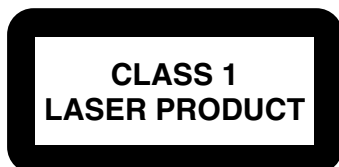

(FIN) Varoitus!

Avatussa laitteessa ja suojalukituksen ohitettaessa olet alttiina näkymättömälle laserisäteilylle. Älä katso säteeseen!

(GB)

After servicing and before returning the set to customer perform a leakage current measurement test from all exposed metal parts to earth ground, to assure no shock hazard exists. The leakage current must not exceed 0.5mA.

(F)

"Pour votre sécurité, ces documents doivent être utilisés par des spécialistes agréés, seuls habilités à réparer votre appareil en panne".

TECHNICAL SPECIFICATIONS

GENERAL

Mains voltage	-/21M : 110 - 127 / 220 - 240V -/33 : 230V \pm 10%	Grid	-/21M 10kHz -/21M/33 : 9kHz
Mains frequency	-/21M : 50 / 60 Hz Switchable -/33 : 50 Hz	IF frequency	: 450 kHz \pm 1 kHz
Battery	remote : 3 V (R6 x 2)	Sensitivity	: \geq 18 dB S9 / 300kHz
Power consumption	normal : 26 W Standby : < 3 W	IF rejection	: < 64 dB
Clock accuracy	: < 4 seconds per day	Distortion at RF=50mV, M=80%	: < 5%
Dimension (W x H x D)	: 154 x 222 x 215 mm	Image rejection ratio	: < 40 dB
Weight (without speakers)	: 2.95 Kg		

AMPLIFIER

Output power	mains : 2 x 5 W RMS
Speaker impedance	: 2 x 3 ohm
Frequency response within \pm 3dB	: 60 Hz - 16 kHz
Dynamic Bass Boost	: DBB On, DBB Off
Digital Sound Control	: Flat/Classic/Rock/Pop
Headphone output at 32 Ω	: 900mV \pm 3dB (Max Vol.)

TUNER - FM SECTION

Tuning range	-/21M/33 : 87.5 - 108 MHz
Grid	-/21M : 100kHz -/21M/33 : 50kHz
IF frequency	: 10.7 MHz \pm 0.02 MHz
Sensitivity	: < 22 μ V at 26dB S/N
Selectivity	300kHz : 45 dB
IF rejection	: 85 dB
Image rejection	: > 25 dB
Distortion at RF1mV, Dev. 75kHz	: < 3%
-3 dB Limiting Point	: < 23.5 μ V
Crosstalk at RF1mV, Dev. 40kHz	: > 18 dB

TUNER - AM SECTION

Tuning range	MW -/21M : 530 - 1700 kHz -/21M/33 : 531 - 1602 kHz
--------------	--

AUDIO CASSETTE RECORDER

Frequency response	Normal : 80 - 10000 Hz (8dB)
Wow & flutter	: \leq 0.35 % DIN
Tape speed	: 4.76 cm/s \pm 3 %
Fast wind/Rewind C60	: < 130 s
Bias system	: 75 kHz \pm 5
Channel separation	1kHz : > 18 dB
Channel difference at overall	: \leq 3 dB
S/N ratio (unw.)	Ferro : \geq 40 (x2)dB
S/N ratio (A-wght.)	Ferro : \geq 45 dBA

DISC PLAYER

Frequency response	: 63Hz - 14kHz \leq \pm 3dB
S/N ratio (A-wght.)	: > 62 dBA
Total harmonic distortion	: < 1.5 %
Outband attenuation	: > 35 dB for Freq > 40kHz
Emphasis	: 15/50 μ S
Channel separation	1 kHz : 35 dB
Channel unbalance	: \leq \pm 2 dB
Luminance non-linear distortion	: 0 \pm 5%
Luminance/Chrominance time delay	: < 120 ns
Luminance S/N (Unw., PAL)	: \geq 50 dB

MP3-CD bit rate	: 32K - 320 Kbps
MP3 Sampling frequencies	: 44.1 kHz

SERVICE TOOLS

TORX T10 screwdriver with shaftlength 150mm.....	4822 395 50423
TORX screwdriver set SBC 163.....	4822 295 50145
Audio signal disc SBC 429.....	4822 397 30184
Playability test disc SBC 444.....	4822 397 30245
Test disc 5 (disc without errors) +	
Test disc 5A (disc with dropout errors, black spots and fingerprints)	
SBC 426/426A.....	4822 397 30096
Burn in test disc (65 min. 1kHz signal at -30 dB level without "pause").....	4822 397 30155
Universal test cassette Fe SBC 420.....	4822 397 30071

AVAILABLE ESD PROTECTION EQUIPMENT

anti-static table mat large 1200x650x1.25mm	4822 466 10953
small 600x650x1.25mm	4822 466 10958
anti-static wristband	4822 395 10223
connection box (3 press stud connections, 1M Ω)	4822 320 11307
extendible cable (2m, 2M Ω , to connect wristband to connection box)	4822 320 11305
connecting cable (3m, 2M Ω , to connect table mat to connection box)	4822 320 11306
earth cable (1M Ω , to connect any product to mat or to connection box)	4822 320 11308
KIT ESD3 (combining all 6 prior products - small table mat)	4822 310 10671
wristband tester	4822 344 13999

SERVICE MEASUREMENT

Tuner FW

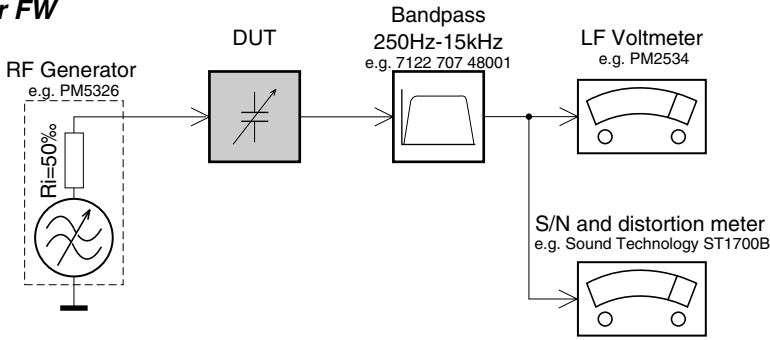

Use a bandpass filter to eliminate hum (50Hz, 100Hz) and disturbance from the pilotone (19kHz, 38kHz).

Tuner AM (MW,LW)

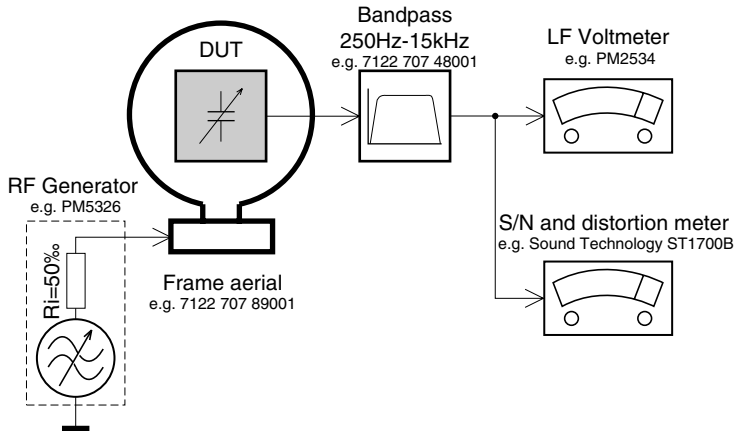

To avoid atmospheric interference all AM-measurements have to be carried out in a Faraday«s cage. Use a bandpass filter (or at least a high pass filter with 250kHz) to eliminate hum (50Hz, 100Hz).

CD

Use Audio Signal Disc SBC429 4822 397 30184 (replaces test disc 3)

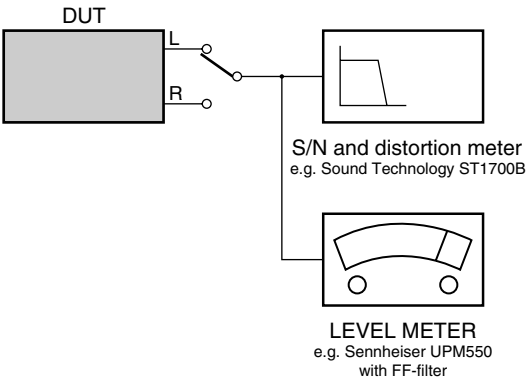

RECORDER

Use Universal Test Cassette Fe SBC420 4822 397 30071

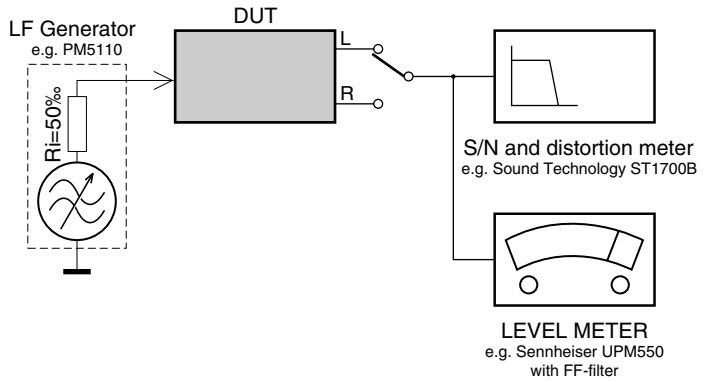

CONNECTION AND CONTROLS

Controls

Controls on the system and remote control

- ① **STANDBY ON** to switch the system on or to standby mode .
- ② **SOURCE** to select the respective sound source : CD, TUNER, TAPE or AUX.
- ③ **PROGRAM / ■** for CD/VCD/MP3-CD...press to stop playback or to clear a programme. for CD/VCD/MP3-CD/Tuner...to enter programming mode.
- ④ **PLAY•PAUSE** for CD/VCD/MP3-CD...to start or interrupt playback.
- ⑤ **MIC** to connect microphone jack.
- ⑥ **MIC LEVEL** to adjust the mixing level for karaoke or microphone recording.
- ⑦ **REPEAT / SLEEP** for CD/VCD to repeat a track/ entire CD for MP3-CD to repeat a track/ an album. for Sleep Timer...to activate/deactivate or set the sleep timer.
- ⑧ **Tape deck**
- ⑨ **Tape Deck Operation**
 - to start recording.
 - ▲ to start playback.
 - ◀ / ▶ to rewind or fast forward.
 - ▲ to stop playback/recording or to open the tape door.
 - || to interrupt playback or recording.
- ⑩ **DSC (DIGITAL SOUND CONTROL)** to select the desired sound effect : OF (flat), RO (rock), PO (pop) or JA (jazz).
- ⑪ **DBB (DYNAMIC BASS BOOST)** to enhance the bass.
- ⑫ **◀◀▶▶** for CD/VCD press and hold to select a desired track. press and hold to fast reverse/forward the disc. for MP3-CD press and hold to select a album. press to select a track. for Tuner press to tune to a lower or higher radio frequency. for Clock to set the hours and minutes.
- ⑬ **VOLUME (VOL +/-)** to increase or decrease the volume .
- ⑭ **Display screen** to view the current status of the system.
- ⑮ connect headphones.
- ⑯ **Disc tray**
- ⑰ **OPEN/CLOSE** ▲ to open or close the disc tray.
- ⑱ **NTSC / PAL** to select the video output for NTSC or PAL setting.
- ⑲ **SLEEP** to set the sleeping time.
- ⑳ **BAND** for Tuner to select waveband : FM or MW.
- ㉑ **Numeric keys (0 - 9, +10)** (numbers consisting more than two figures must be keyed in within 2 seconds) for CD/VCD/MP3-CD...to direct key in a track number. for Tuner to select a preset radio station.
- ㉒ **SHUFFLE** to play CD tracks in random order.
- ㉓ **REPEAT** to repeat a track / album/ entire disc.
- ㉔ **REW ◀ / ▶ FWD** for CD press and hold to fast reverse/forward the disc. for VCD press to fast reverse/forward the disc. for MP3-CD press and hold to select a album. for Tuner press to tune to a lower or higher radio frequency.

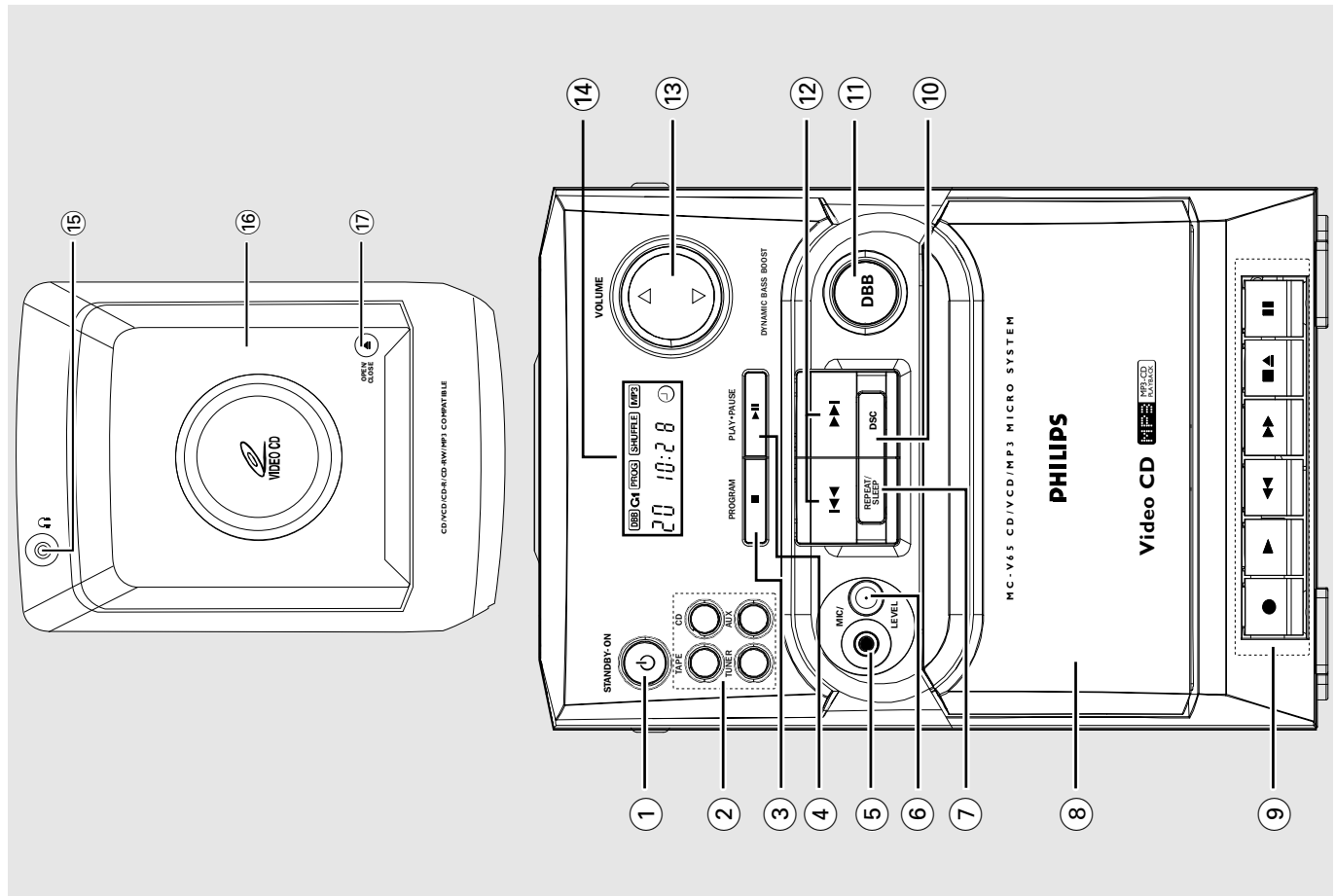

CONNECTION AND CONTROLS

Preparations

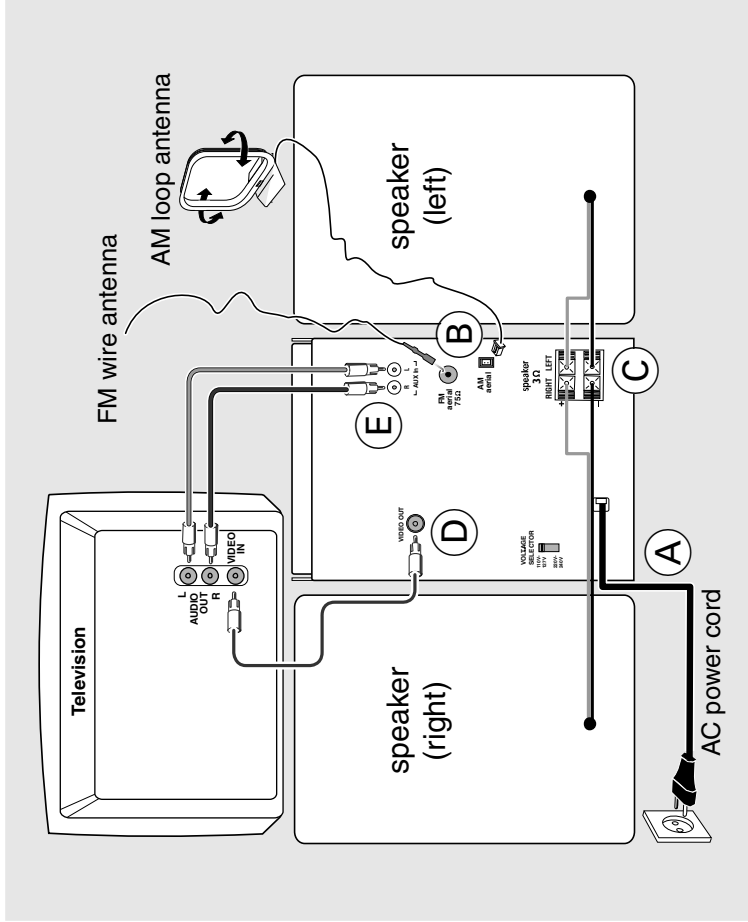

Rear connections

The type plate is located at the rear of the system.

(A) Power

- Before connecting the AC power cord to the wall outlet, ensure that the following are done:
 - If your system is equipped with a Voltage Selector, set the VOLTAGE SELECTOR to the local power line voltage.
 - All other connections have been made.

WARNING!

- For optimal performance, use only the original power cable.
- Never make or change connections with the power switched on.

(B) Antennas Connection

Connect the supplied AM loop antenna and FM antenna to the respective terminals. Adjust the position of the antenna for optimal reception.

AM Antenna

- Position the antenna as far as possible from a TV, VCR or other radiation source.

FM Antenna

- For better FM stereo reception, connect an outdoor FM antenna to the FM AERIAL terminal.

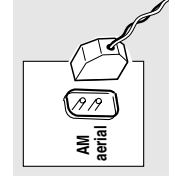

Controls

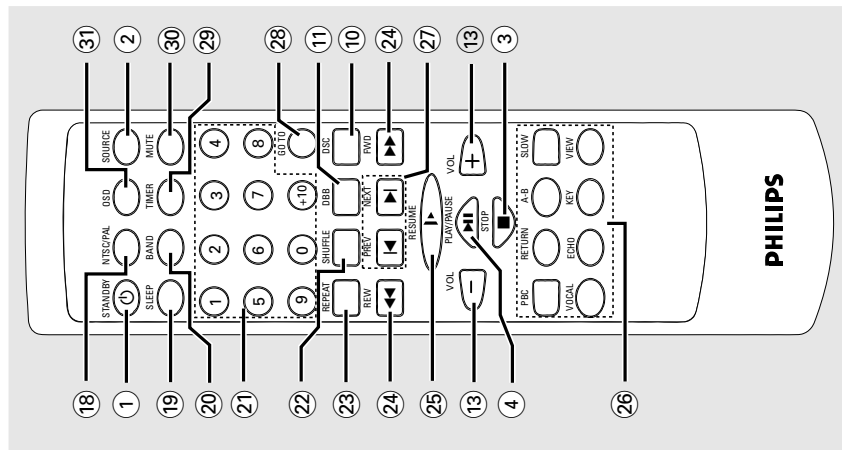

Notes for remote control:

- While the system is in active mode, select the source you wish to control by pressing SOURCE key on the remote control.
- Then select the desired function (for example \blacktriangle , \blacktriangleleft , \blacktriangleright).

- (25) RESUME \blacktriangleright** to continue playback again from where you have stopped (for VCD with PBC switched off).
- (26) VCD operations (on remote control only)**
 - PBC** to switch on or off the playback control mode (for VCD version 2.0 only).
 - RETURN** to return to the previous menu level during playback (for VCD with PBC switched on).
 - A - B** to playback a certain scene or passage of a CD/VCD repeatedly.
 - SLOW** to watch the VCD at a slower speed.
 - VIEW** to scan through a VCD or a specific track (for VCD with PBC switched off)
 - KEY** to display and set the key tone level.
 - ECHO** to adjust the echo level for karaoke after inserted the microphone.
 - VOCAL** to fade out the original vocal from a Karaoke VCD or to switch between mono or stereo mode during audio disc playback.
- (27) PREV \blacktriangleleft / \blacktriangleright NEXT** for CD/VCD/MP3-CD...to select a desired track.
- for Tuner to select a preset radio station.
- for Clock to set the hour's and minutes.
- (28) GOTO** to playback at any chosen time on the CD/VCD.
- (29) TIMER** to activate the timer/clock-function.
- (30) MUTE** to enable or disable the sound output.
- (31) OSD** to switch on or off the On Screen Display on the TV.

CONNECTION AND CONTROLS

Preparations

(C) Speakers Connection

Front Speakers

Connect the speaker wires to the SPEAKERS terminals, right speaker to "RIGHT" and left speaker to "LEFT", coloured (marked) wire to "+" and black (unmarked) wire to "-".

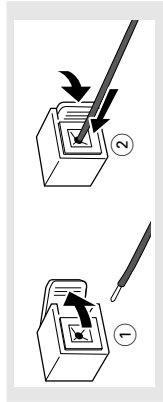

- Fully insert the stripped portion of the speaker wire into the terminal as shown.

Notes:

- For optimal sound performance, use the supplied speakers.
- Do not connect more than one speaker to any one pair of + / - speaker terminals.
- Do not connect speakers with an impedance lower than the speakers supplied. Please refer to the SPECIFICATIONS section of this manual.

(D) Connecting a TV

Connect the **VIDEO OUT** terminal at the rear of the system to the TV or VCR **VIDEO IN** for viewing or recording.

Note:

- To avoid magnetic interference, do not position the front speakers too close to your TV.

(E) Connecting other equipment to your system

Use a cinch cable to connect **AUX IN** to the analogue audio out terminals of an external equipment (TV, VCR, Laser Disc player, DVD player or CD Recorder).

Note:

- If you are connecting to equipment with only mono output (a single audio out terminal), connect it to the **AUX IN** left terminal. Alternatively, you can use a "single to double" cinch cable, but the output sounds still remain mono.

Inserting batteries into the remote control

Insert two batteries type R03 or AAA (not supplied) into the remote control with the correct polarity as indicated by the "+" and "-" symbols inside the battery compartment.

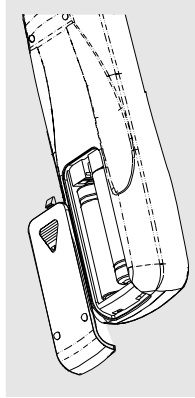

CAUTION!

- Remove batteries if they are exhausted or will not be used for a long time
- Do not use old and new or different types of batteries in combination.
- Batteries contain chemical substances, so they should be disposed off properly.

For more information on operation instruction please visit Philips Audio internet site : <http://www.audio.philips.com>

DISASSEMBLY DIAGRAM

- A. To remove Cabinet Rear
- B. To remove CD Tray
- C. To remove Main Board
- D. To remove VCD & Tape Board
- E. To remove Tape Deck
- F. To remove Front Board
- G. To remove Cassette Key Plate
- H. To remove Transformer Holder

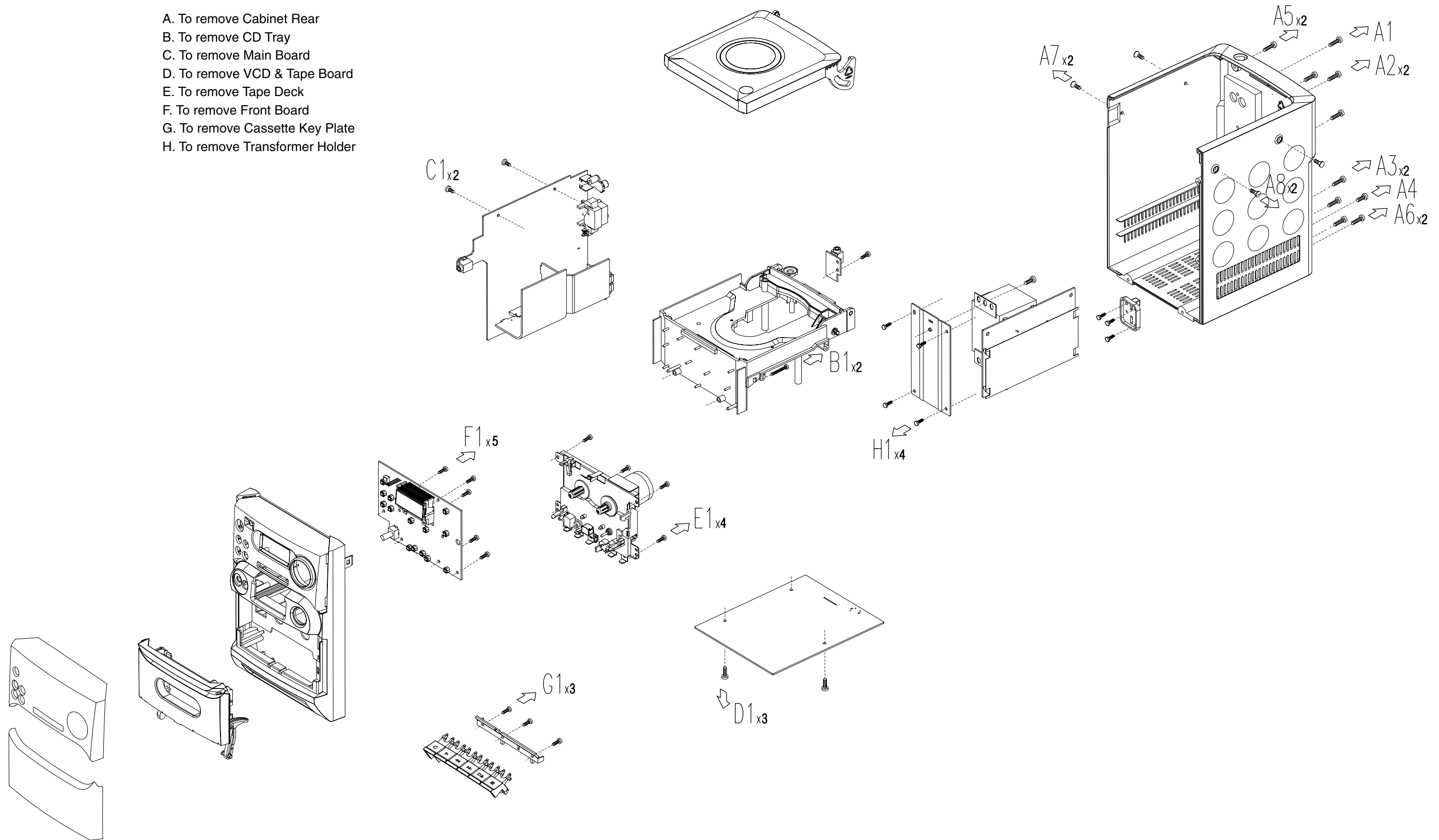

Abbreviations and Pin-description of CD Ics**SERVO PROCESSOR SAA7324H**

SYMBOL	PIN	DESCRIPTION
HFREF	1	comparator common mode input
HFIN	2	comparator signal input
ISLICE	3	current feedback output from data slicer
V _{SSA1}	4 ⁽¹⁾	analog ground 1
V _{DDA1}	5 ⁽¹⁾	analog supply voltage 1
I _{ref}	6	reference current output pin
V _{RIN}	7	reference voltage for servo ADC's
D1	8	unipolar current input (central diode signal input)
D2	9	unipolar current input (central diode signal input)
D3	10	unipolar current input (central diode signal input)
D4	11	unipolar current input (central diode signal input)
R1	12	unipolar current input (satellite diode signal input)
R2	13	unipolar current input (satellite diode signal input)
V _{SSA2}	14 ⁽¹⁾	analog ground 2
CROUT	15	crystal/resonator output
CRIN	16	crystal/resonator input
V _{DDA2}	17 ⁽¹⁾	analog supply voltage 2
LN	18	DAC left channel differential output - negative
LP	19	DAC left channel differential output - positive
V _{neg}	20	DAC negative reference input
V _{pos}	21	DAC positive reference input
RN	22	DAC right channel differential output - negative
RP	23	DAC right channel differential output - positive
SELPLL	24	selects whether internal clock multiplier PLL is used
TEST1	25	test control input 1; this pin should be tied LOW
CL16	26	16.9344 MHz system clock output
DATA	27	serial d4(1)ata output (3-state)
WCLK	28	word clock output (3-state)
SCLK	29	serial bit clock output (3-state)
EF	30	C2 error flag output (3-state)
TEST2	31	test control input 2; this pin should be tied LOW
KILL	32	kill output (programmable; open-drain)
V _{SSD1}	33 ⁽¹⁾	digital ground 2
V2/V3	34	versatile I/O: input versatile pin 2 or output versatile pin 3 (open-drain)
WCLI	35	word clock iutput (for data loopback to DAC)
SDI	36	serial data input (for data loopback to DAC)
SCLI	37	serial bit clock input (for data loopback to DAC)
RESET	38	power-on reset input (active LOW)
SDA	39	microcontroller interface data I/O line (open-drain output)
SCL	40	microcontroller interface clock line input

Abbreviations and Pin-description of CD Ics**SERVO PROCESSOR SAA7324H**

SYMBOL	PIN	DESCRIPTION
RAB	41	microcontroller interface R/W and load control line input (4-wire bus mode)
SILD	42	microcontroller interface R/W and load control line input (4-wire bus mode)
STATUS	43	servo interrupt request line/decoder status register output (open-drain)
TEST3	44	test control input 3; this pin should be tied LOW
RCK	45	subcode clock input
SUB	46	P-to-W subcode bits output (3-state)
SFSY	47	subcode frame sync output (3-state)
SBSY	48	subcode block sync output (3-state)
CL11/4	49	11.2896 MHz or 4.2336 MHz (for microcontroller) clock output
V _{SSD2}	50 ⁽¹⁾	digital ground 3
DOBM	51	bi-phase mark output (externally buffered; 3-state)
V _{DD1(P)}	52 ⁽¹⁾	digital supply voltage 2 for periphery
CFLG	53	correction flag output (open-drain)
RA	54	radial actuator output
FO	55	focus actuator output
SL	56	sledge control output
V _{DD2(C)}	57 ⁽¹⁾	digital supply voltage 3 for core
V _{SSD3}	58 ⁽¹⁾	digital ground 4
MOTO1	59	motor output 1; versatile (3-state)
MOTO2	60	motor output 2; versatile (3-state)
V4	61	versatile output pin 4
V5	62	versatile output pin 5
V1	63	versatile input pin 1
LDON	64	laser drive on output (open-drain)

Note : All supply pins must be connected to the same external power supply voltage.

BLOCK DIAGRAM OF INTEGRATED CIRCUIT

SERVO PROCESSOR SAA7324H

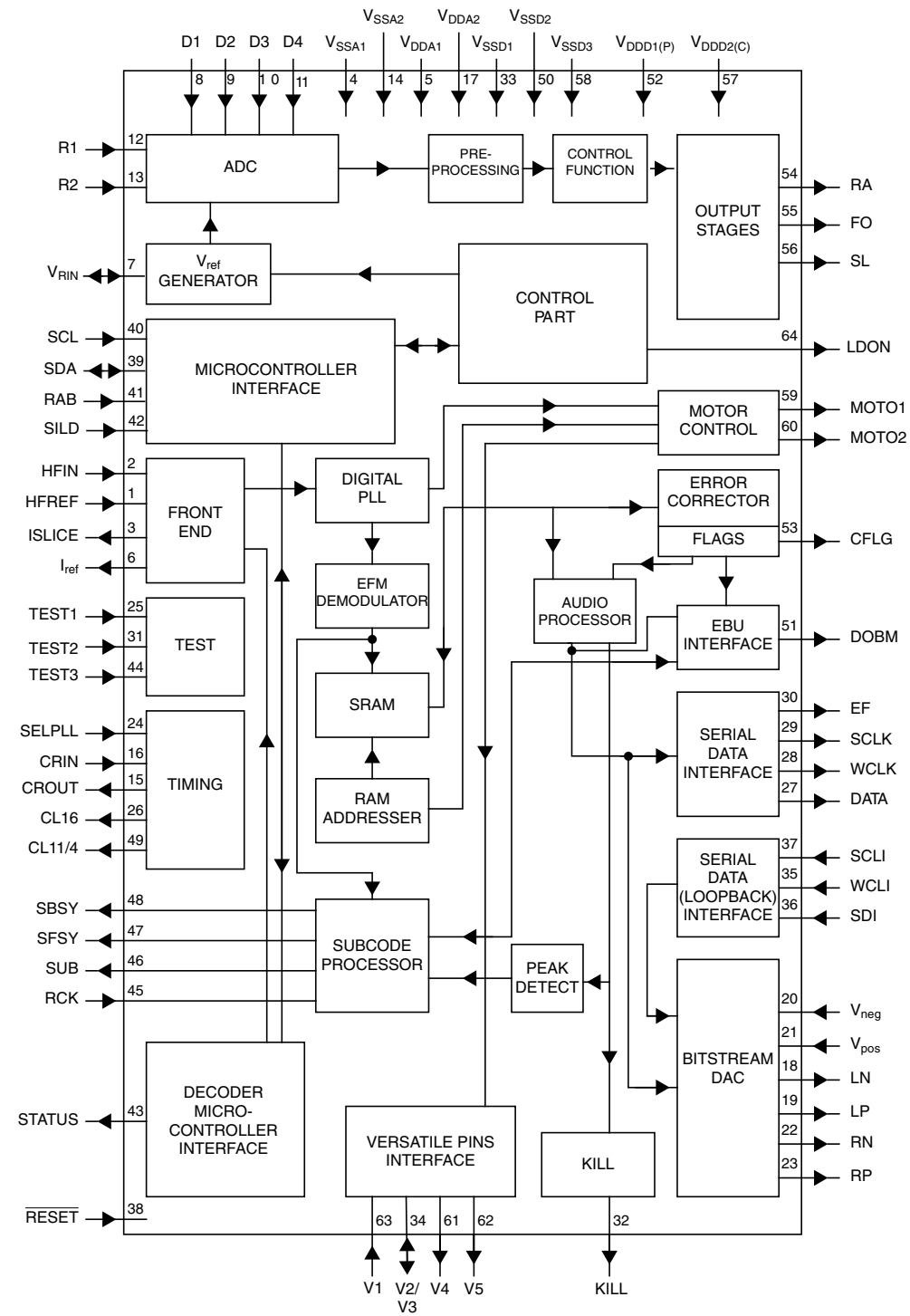

BLOCK DIAGRAM OF INTEGRATED CIRCUIT

MM1469XH

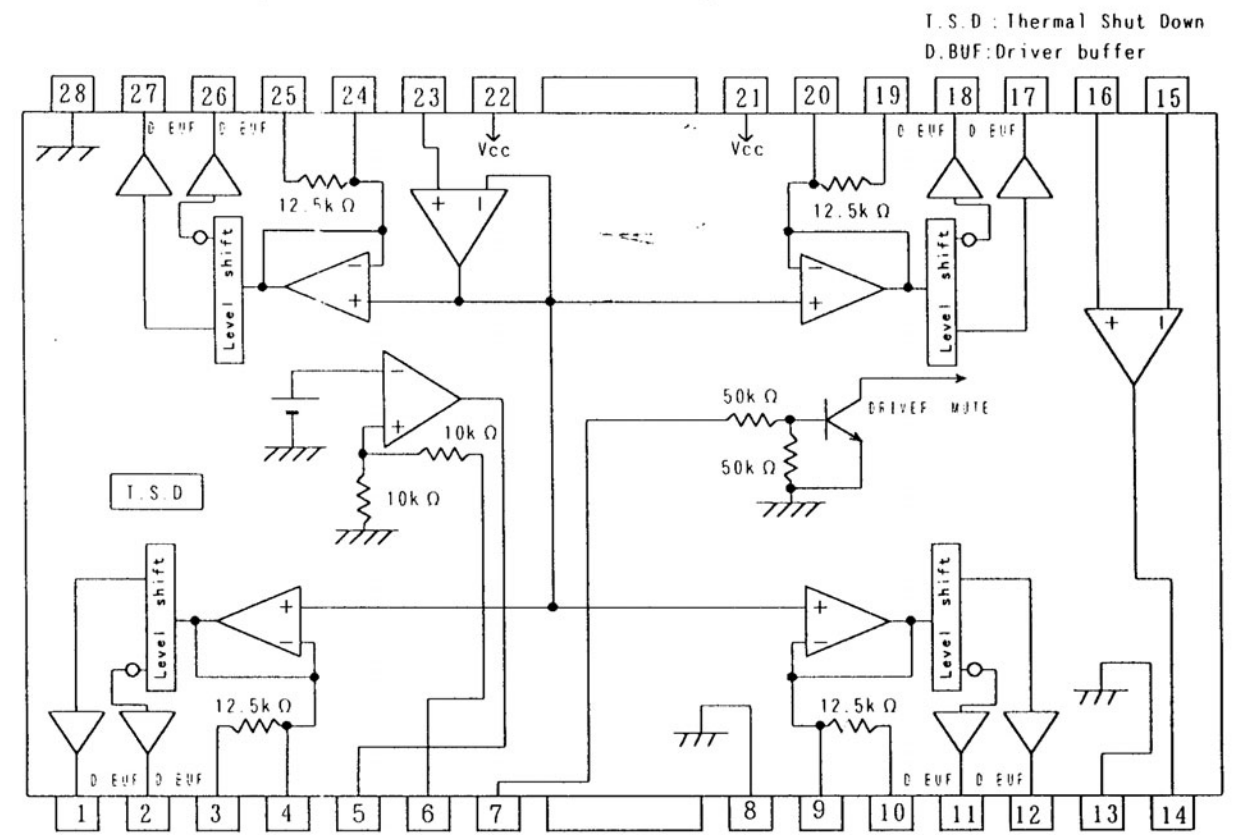

BLOCK DIAGRAM OF INTEGRATED CIRCUIT

TZA1024

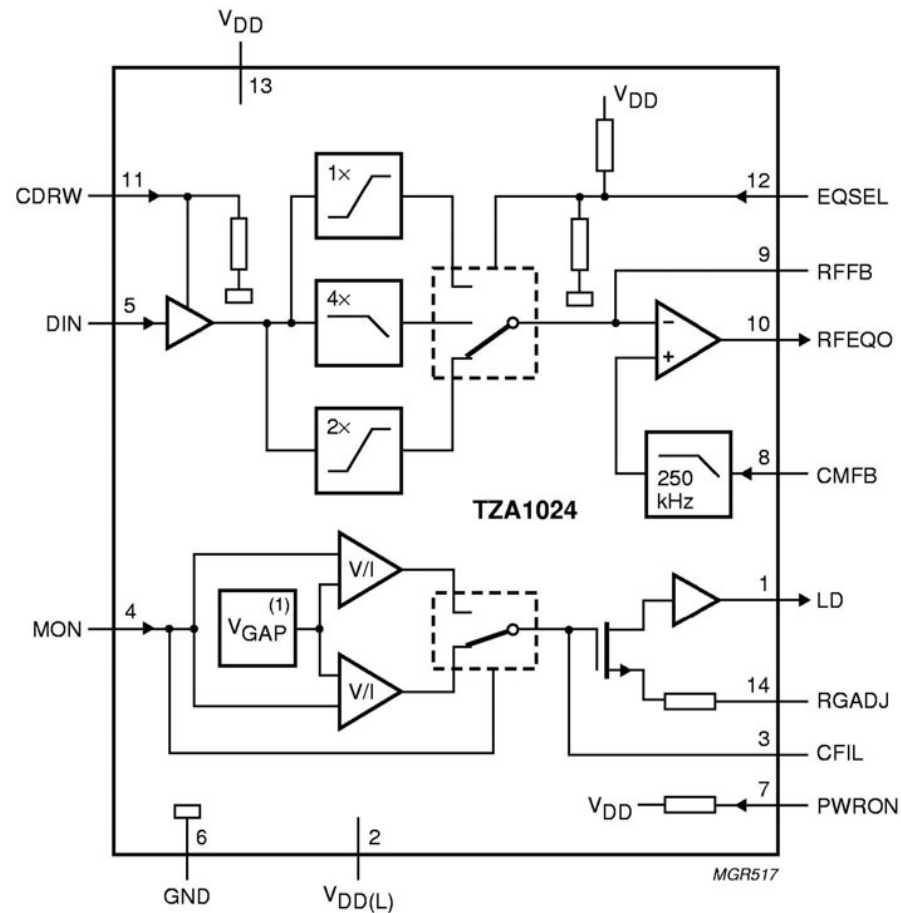

PINS DESCRIPTION OF IC TZA1024

PIN FUNCTION

SYMBOL	PIN	DESCRIPTION
LD	1	current output to laser diode
V _{DD(L)}	2	laser supply voltage
CFIL	3	external filter capacitor
MON	4	laser monitor diode input
DIN	5	central diode input
GND	6	ground
PWRON	7	power-on select input
CMFB	8	common mode feedback voltage input
RFFB	9	external RF feedback resistor
RFEQO	10	RF amplifier output
CDRW	11	gain select input for CD-A/V, CD-R/W
EQSEL	12	equalizer/speed select input (n = 1, 2 or 4)
V _{DD}	13	supply voltage
RGADJ	14	external laser supply gain adjust resistor

BLOCK DIAGRAM OF INTEGRATED CIRCUIT

DIGITAL VIDEO ENCODER SPCA711A

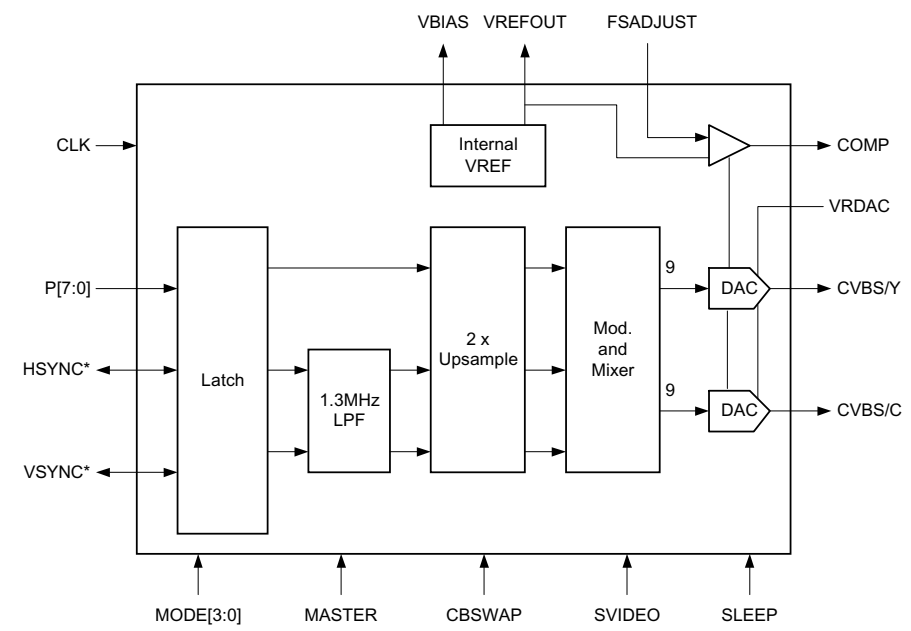

PINOUT MAP OF SPCA711A

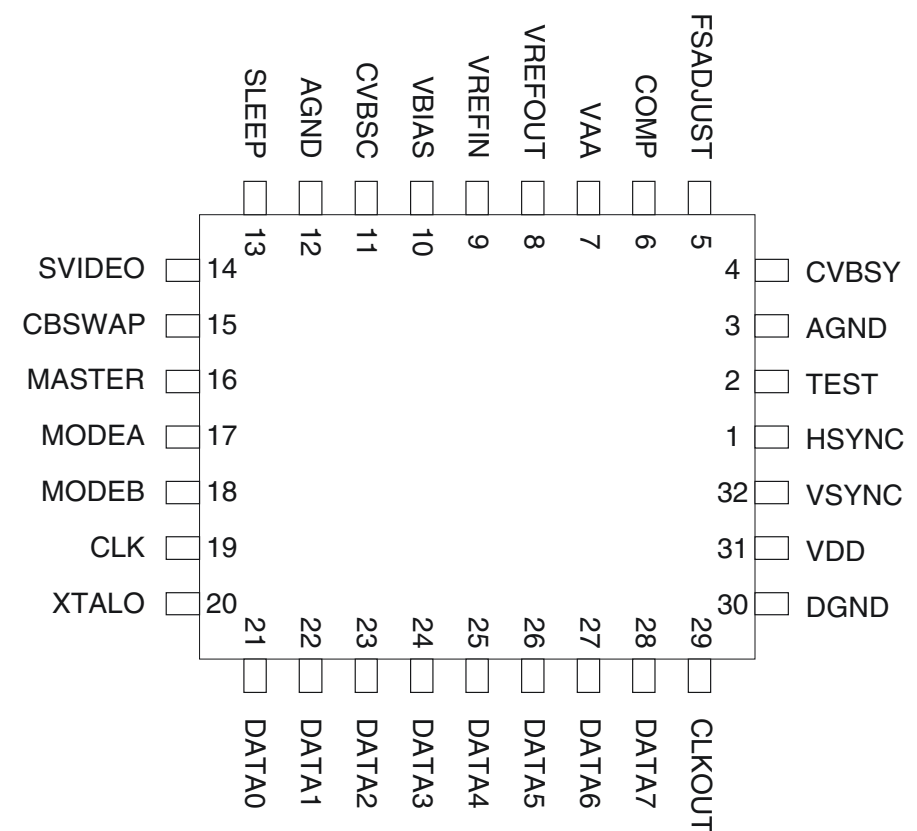

PINS DESCRIPTION OF DIGITAL VIDEO ENCODER SPCA711A

PIN FUNCTION

Mnemonic	PIN No.	Type	Description
DATA[7:0]	21 - 28	I	YCrCb pixel inputs. They are latched on the rising edge of CLK. YCrCb input data conform to CCIR 601.
CLKOUT	29	O	Pixel clock output
VSYNC	32	I/O	Vertical sync input/output. VSYNC is latched/output following the rising edge of CLK.
HSYNC	1	I/O	Horizontal sync input/output. HSYNC is latched/output following the rising edge of CLK.
MASTER	16	I	Master/slave mode selection. A logical high for master mode operation. A logical 0 for slave mode operation.
CBSWAP	15	I	Cr and Cb pixel sequence configuration pin. A logic high swap the Cr and Cb sequence.
SVIDEO	14	I	SVIDEO select input pin. A logic high selects Y/C output. A logic low selects composite video output.
SLEEP	13	I	Power save mode. A logic high on this pin puts the chip into power-down mode. This pin is equal to reset pin. An external logic high pulse should input to the pin when power on.
MODEA	17	I	Mode configuration pin.
MODEB	18	I	Mode configuration pin.
CLK	19	I	27MHz crystal oscillator input. A crystal with 27MHz clock frequency can be connected between this pin and XTALO.
XTALO	20	O	Crystal oscillator output.
TEST	2	I	Test pin. These pins must be connected to DGND.
VREFIN	9	I	Voltage reference input. An external voltage reference must supply typical 1.235V to this pin. A 0.1 μ F ceramic capacitor must be used to de-couple this input to GND. The decoupling capacitor must be as closed as possible to minimize the length of the load. This pin may be connected directly to VREFOUT.
VREFOUT	8	O	Voltage reference output. It generates typical 1.2V voltage reference and may be used to drive VREFIN pin directly.
FSADJ	5	-	Full-Scale adjust control pin. The Full-Scale current of D/A converters can be adjusted by connecting a resistor (RSET) between this pin and ground.

PINS DESCRIPTION OF DIGITAL VIDEO ENCODER SPCA711A

PIN FUNCTION

Mnemonic	PIN No.	Type	Description
VAA	7	-	Analog power pin
AGND	3,12	-	Analog ground pin
COMP	6	-	Compensation pin. A 0.1 μ F ceramic capacitor must be used to bypass this pin to VAA. The lead length must be kept as short as possible to avoid noise.
VBIAS	10	-	DAC bias voltage. Potential normally 0.7V less than COMP.
VDD	31	-	Digital power pin
DGND	30	-	Digital ground pin
CVBSY	4	O	Composite/Luminance output. This is a high-impedance current source output. The output format can be selected by the PAL pin. The CVBSY can drive a 37.5 Ω load.
CVBSC	11	O	Composite/Chroma output. This is a high impedance current source Output. The output format can be selected by the PAL pin. The pin can drive a 37.5 Ω load.

BLOCK DIAGRAM OF INTEGRATED CIRCUIT

VCD DECODER SPCA702A

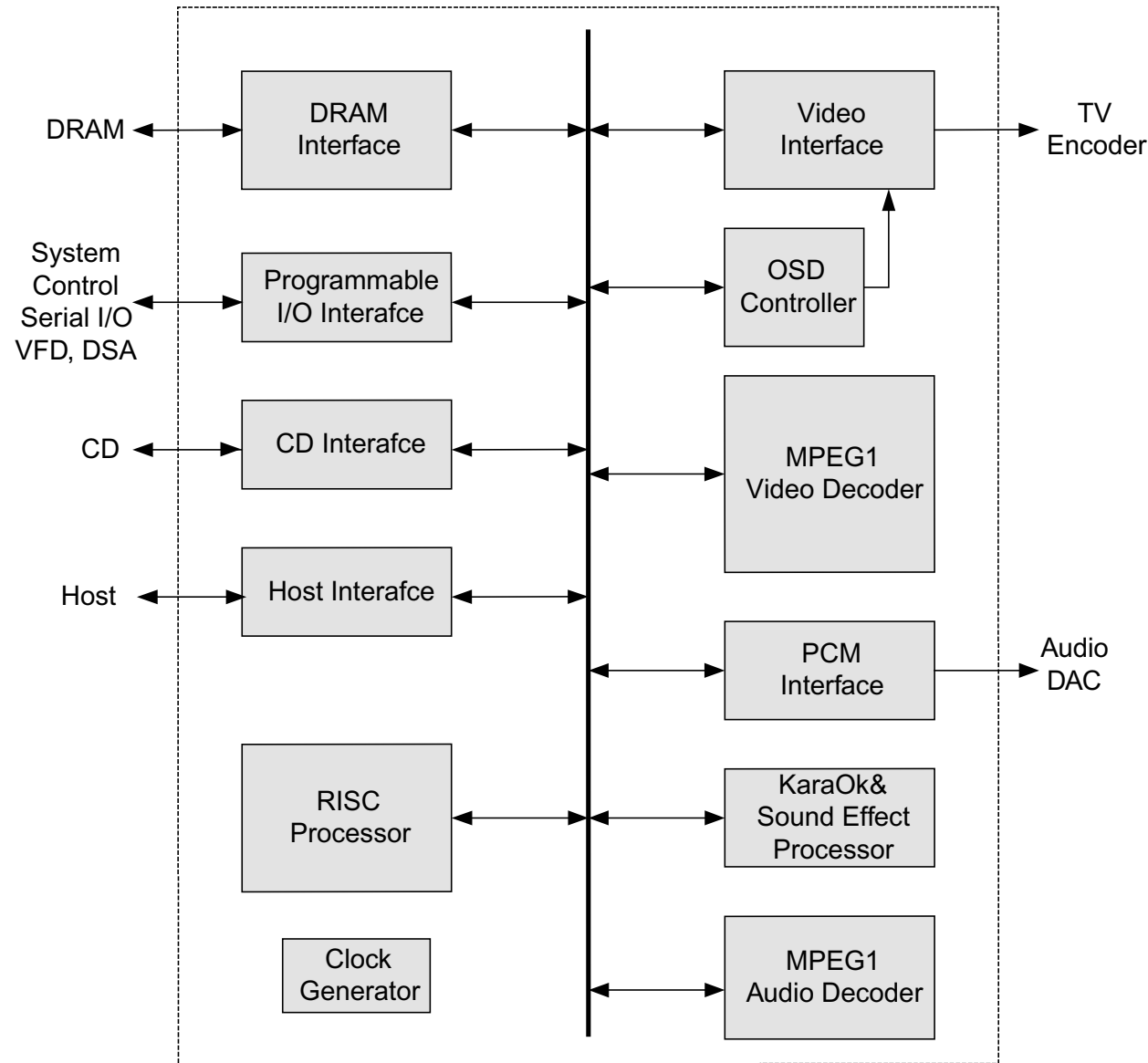

PIN MAP OF INTEGRATED CIRCUIT

VCD DECODER SPCA702A

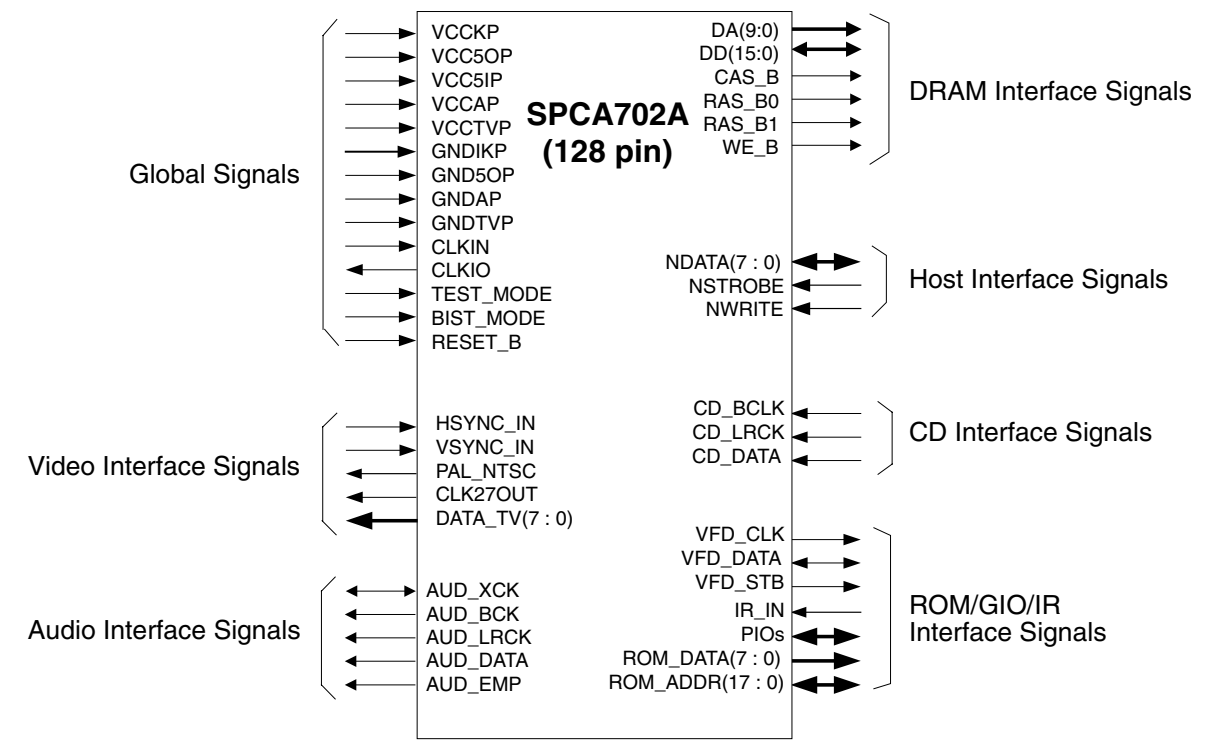
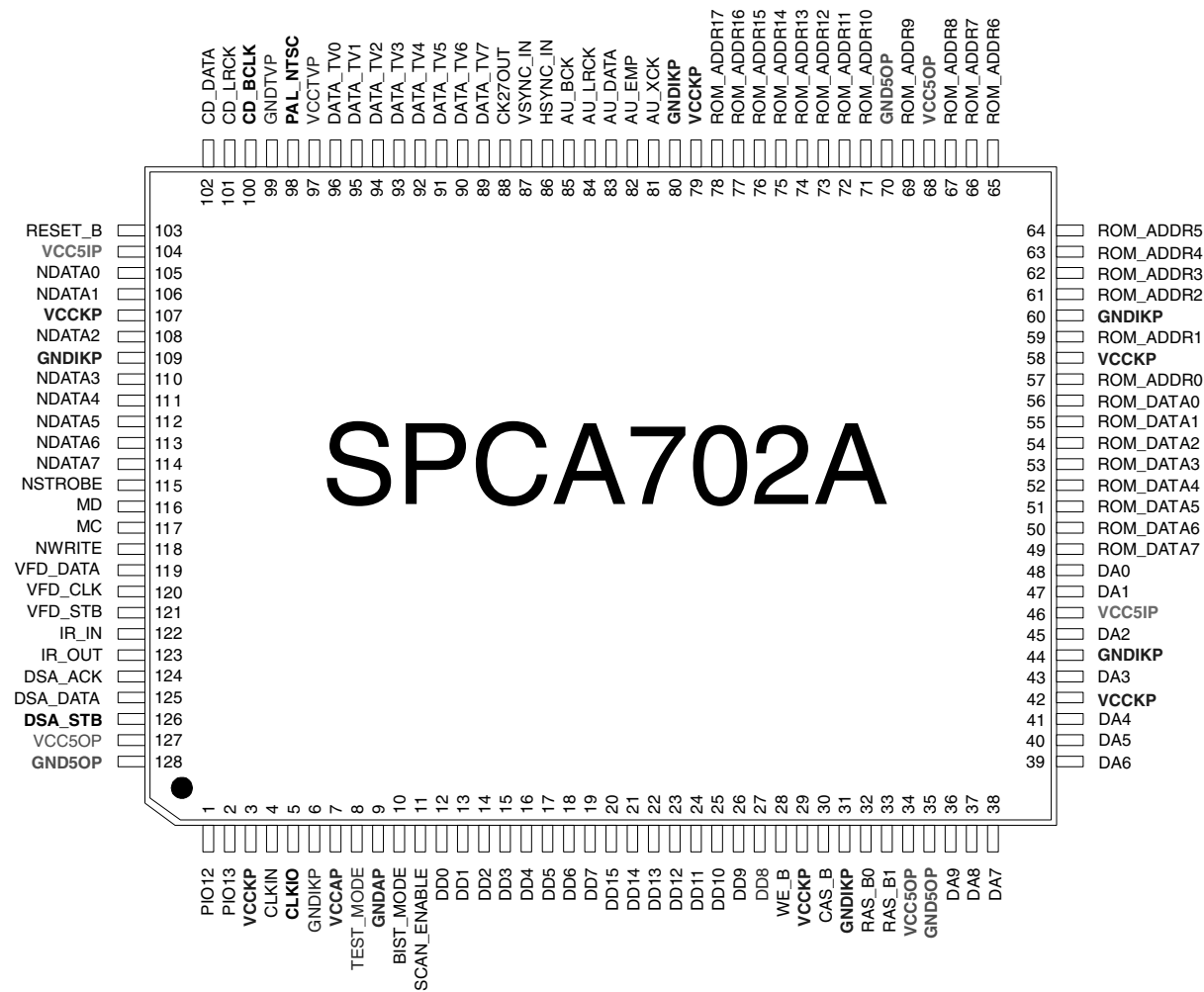

PINS DESCRIPTION OF VCD DECODER SPCA702A

PIN FUNCTION

Name	I/O	Pin	Description
VCC5OP,VCC5IP	I	34,46,68,104,127	This pin supplies 5 volts to I/O pad.
GND5OP	I	35,70,128	Ground for I/O buffers.
VCCKP	I	3,29,42,58,79,107	This pin supplies 3.3 volts to internal logic.
GNDIKP	I	6,31,44,60,80,109	Ground for internal logic and input pad.
VCCAP	I	7	This pin supplies 3.3 volts to internal PLL circuit.
GNDAP	I	9	This pin is the ground for internal PLL circuit.
VCCTVP	I	97	This pin supplies 3.3 volts or 5 volts to TV encoder associated interface signals.
GNDTVP	I	99	This pin is ground for TV encoder associated interface signals.
CLKIN, CLKIO	I/O	4-5	These two pins connect to 27 MHz crystal.
TEST_MODE	I	8	Bringing this pin high will put the chip in test mode. This pin should normally be low.
BIST_MODE	I	10	Bringing this pin high will put the chip in bist test mode. This pin should normally be low.
RESET_B	I	103	This signal is active low and must be active for at least 25 CLK27OUT clock cycles. After reset, the SPCA702A will be in the initialization state.
CD_DATA	I	102	This pin is input for serial data from CD-DSP.
CD_LRCK	I	101	CD_LRCK provides 16-bit word synchronization to the SPCA702A and has several programmable features, such as polarity, delay and pulse mode.
CD_BCK	I	100	The CD_BCK is the CD-Decoder bit clock. The SPCA702A can accept multiple BCK rates.
HSYNC_IN	I	86	Horizontal sync signal input from TV encoder.
VSYNC_IN	I	87	Vertical sync signal input from TV encoder.
DATA_TV(7:0)	O	96-99	These pins form the video data output bus. It contains multiplexed Luminance and Chrominance video data.
PAL_NTSC	O	98	This pin controls the PAL/NTSC mode of TV encoder.
CLK27OUT	O	88	27 MHz video pixel clock output to the TV encoder.
AUD_XCK	I/O	81	When the CA700A is programmed for external audio clock mode, the audio clock will come from this signal. When programmed for internal audio clock, this signal will reflect the internal audio clock.
AUD_BCK	O	85	This pin is the audio bit clock output. Depending on audio output mode, this signal can be derived from the master clock or be AUD_XCK divided by 8. It can be either 48 or 32 times the sampling clock.
AUD_LRCK	O	84	This pin is used as the Left/Right data channel indicator.
AUD_DATA	O	83	This pin is used as the serial audio data clocked out relative to AUD_BCK.
AUD_EMP	O	82	This signal is used to control the de-emphasis circuitry of the audio output DACs. In CD-DA pass-through mode, this output follows the state of the CD_EMP signal; when in VCD mode, this pin follows the LSB of the emphasis field of the MPEG-1 audio header.
DA(11:0)	O	48-47,45,43,41-36	Address bus of fast-page or EDO DRAM
DD(15:0)	I/O	12-19,27-20	DRAM access data bus. The direction is determined by DR_WE_L signal.
CAS_B	O	30	DRAM CAS signals.
RAS_B	O	32-33	DRAM RAS signals for bank 1 to 0.
WE_B	O	28	DRAM write enable signal.
NDATA(7:0)	I/O	105-106,108,110-114	Bus interface between host and Mpeg chip.
NSTROBE	I	115	Strobe signal for other host interface signals
NWRITE	I	118	write/read enable

PINS DESCRIPTION OF VCD DECODER SPCA702A

PIN FUNCTION

Name	I/O	Pin	Description
ROM_DATA(7:0)	I	56-49	Generic 8-bit parallel ROM data bus.
ROM_ADDR(17:0)	O	57,59,61-67,69,71-78	Generic ROM address bus.
VFD_DATA	I/O	119	Data signal for VFD.
VFD_CLK	O	120	Clock signal for VFD.
VFD_STB	O	121	Strobe signal for VFD.
DSA_ACK	I/O	124	Ack signal for DSA interface
DSA_DATA	I/O	125	Data signal for DSA interface.
DSA_STB	I/O	126	Strobe signal for DSA interface.
IR_IN	I	122	IR input pin. This input supports both NEC and Philips format IR signal.
IR_OUT	O	123	IR output pin.

BLOCK DIAGRAM OF INTEGRATED CIRCUIT

EPROM W27C020

PIN CONFIGURATIONS

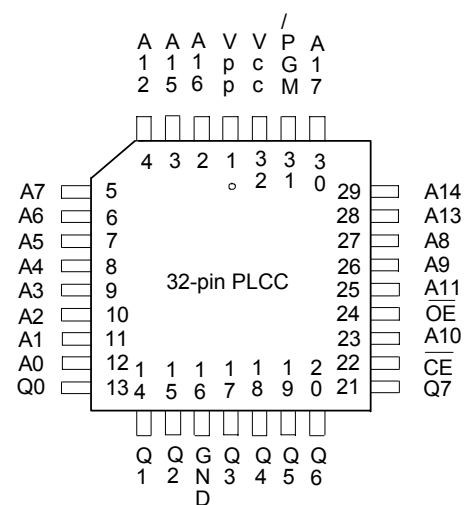
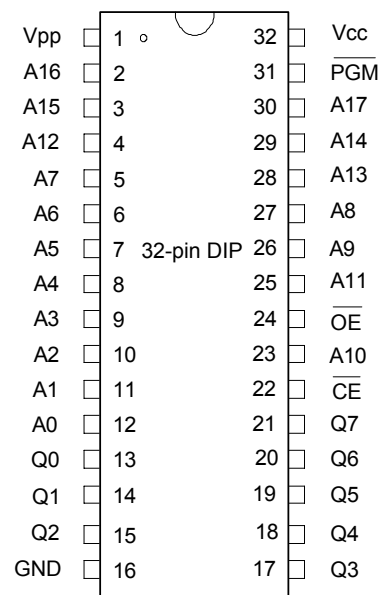

BLOCK DIAGRAM OF INTEGRATED CIRCUIT

EPROM W27C020

BLOCK DIAGRAM

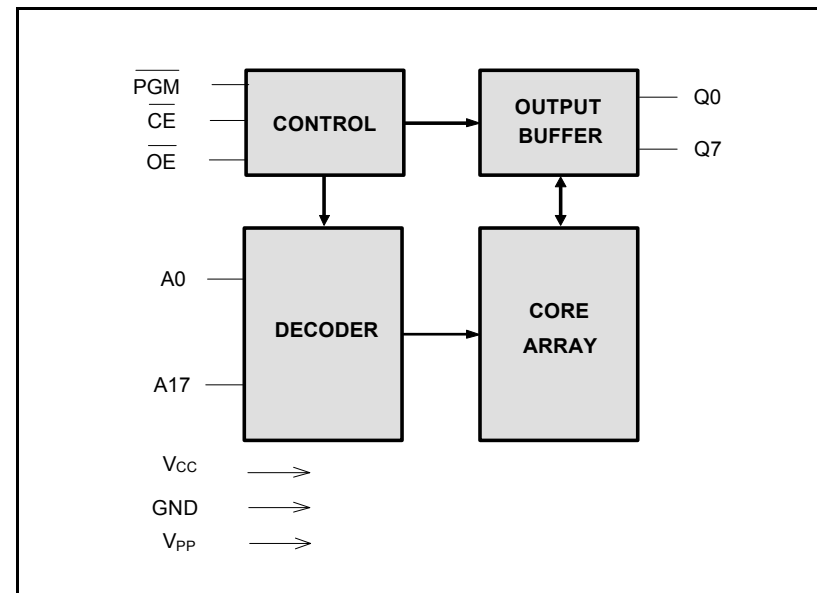

PIN DESCRIPTION

SYMBOL	DESCRIPTION
A0-A17	Address Inputs
Q0-Q7	Data Inputs/Outputs
\overline{CE}	Chip Enable
\overline{OE}	Output Enable
\overline{PGM}	Program Enable
VPP	Program/Erase Supply Voltage
VCC	Power Supply
GND	Ground

BLOCK DIAGRAM OF INTEGRATED CIRCUIT

LCD DRIVER HT1621B

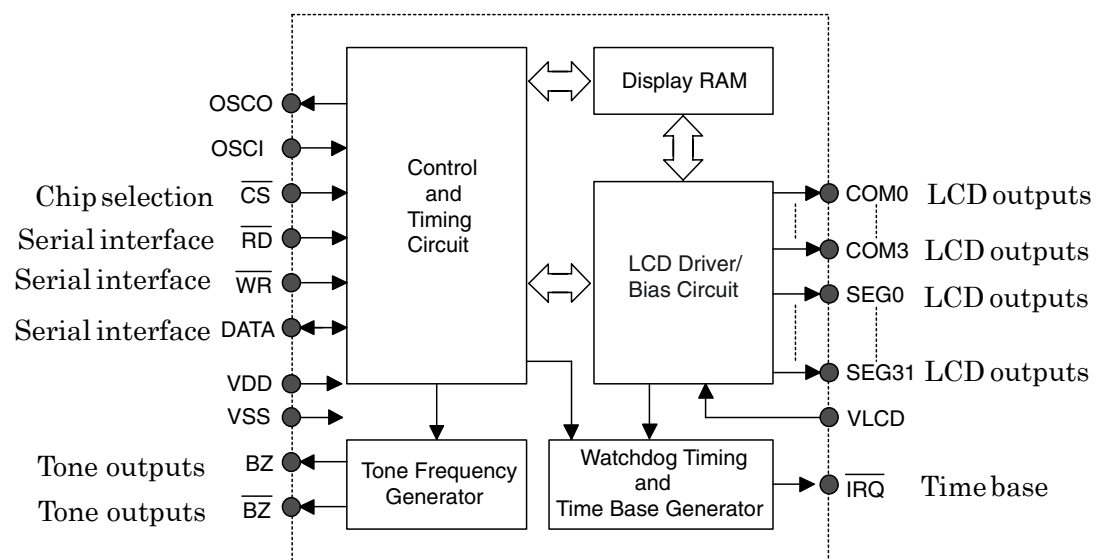

PINS DESCRIPTION OF LCD DRIVER HT1621B

PIN FUNCTION

Pad No.	Pad Name	I/O	Function
1	\overline{CS}	I	Chip selection input with pull-high resistor When the \overline{CS} is logic high, the data and command read from or written to the HT1621 are disabled. The serial interface circuit is also reset. But if \overline{CS} is at logic low level and is input to the \overline{CS} pad, the data and command transmission between the host controller and the HT1621 are all enabled.
2	\overline{RD}	I	READ clock input with pull-high resistor Data in the RAM of the HT1621 are clocked out on the falling edge of the \overline{RD} signal. The clocked out data will appear on the DATA line. The host controller can use the next rising edge to latch the clocked out data.
3	\overline{WR}	I	WRITE clock input with pull-high resistor Data on the DATA line are latched into the HT1621 on the rising edge of the \overline{WR} signal.
4	DATA	I/O	Serial data input/output with pull-high resistor
5	VSS	□	Negative power supply, ground
7	OSCI	I	The OSCI and OSCO pads are connected to a 32.768kHz crystal in order to generate a system clock. If the system clock comes from an external clock source, the external clock source should be connected to the OSCI pad. But if an on-chip RC oscillator is selected instead, the OSCI and OSCO pads can be left open.
6	OSCO	O	
8	VLCD	I	LCD power input
9	VDD	□	Positive power supply
10	\overline{IRQ}	O	Timebase or WDT overflow flag, NMOS open drain output
11, 12	BZ, \overline{BZ}	O	2kHz or 4kHz tone frequency output pair
13~16	COM0~COM3	O	LCD common outputs
48~17	SEG0~SEG31	O	LCD segment outputs

BLOCK DIAGRAM OF INTEGRATED CIRCUIT

DRAM MSM514265C

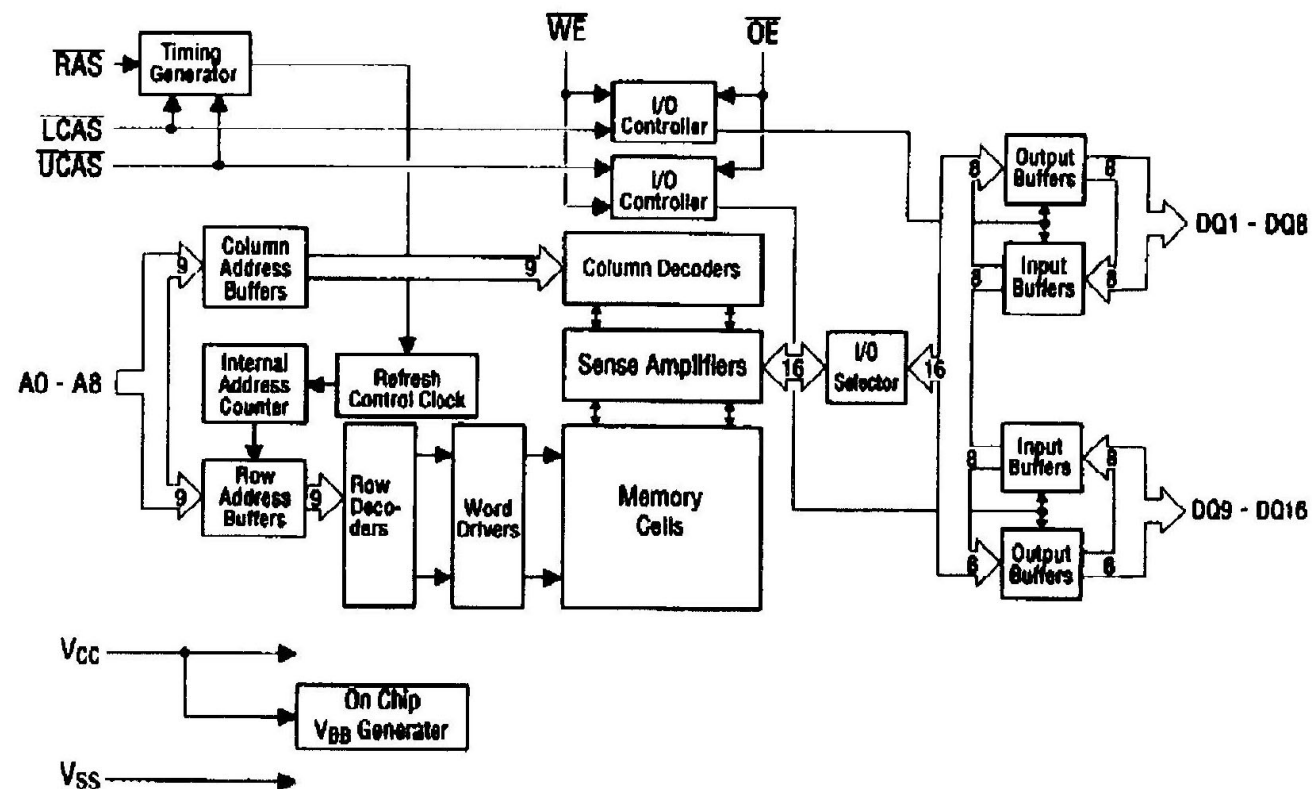

PINS DESCRIPTION OF INTEGRATED CIRCUIT

DRAM MSM514265C

Pin Name	Function
A0 - A8	Address Input
RAS	Row Address Strobe
\overline{LCAS}	Lower Byte Column Address Strobe
\overline{UCAS}	Upper Byte Column Address Strobe
DQ1 - DQ16	Data Input / Data Output
\overline{OE}	Output Enable
\overline{WE}	Write Enable
Vcc	Power Supply (5 V)
Vss	Ground (0 V)
NC	No Connection

BLOCK DIAGRAM OF INTEGRATED CIRCUIT

P8XC54(8)SBBB

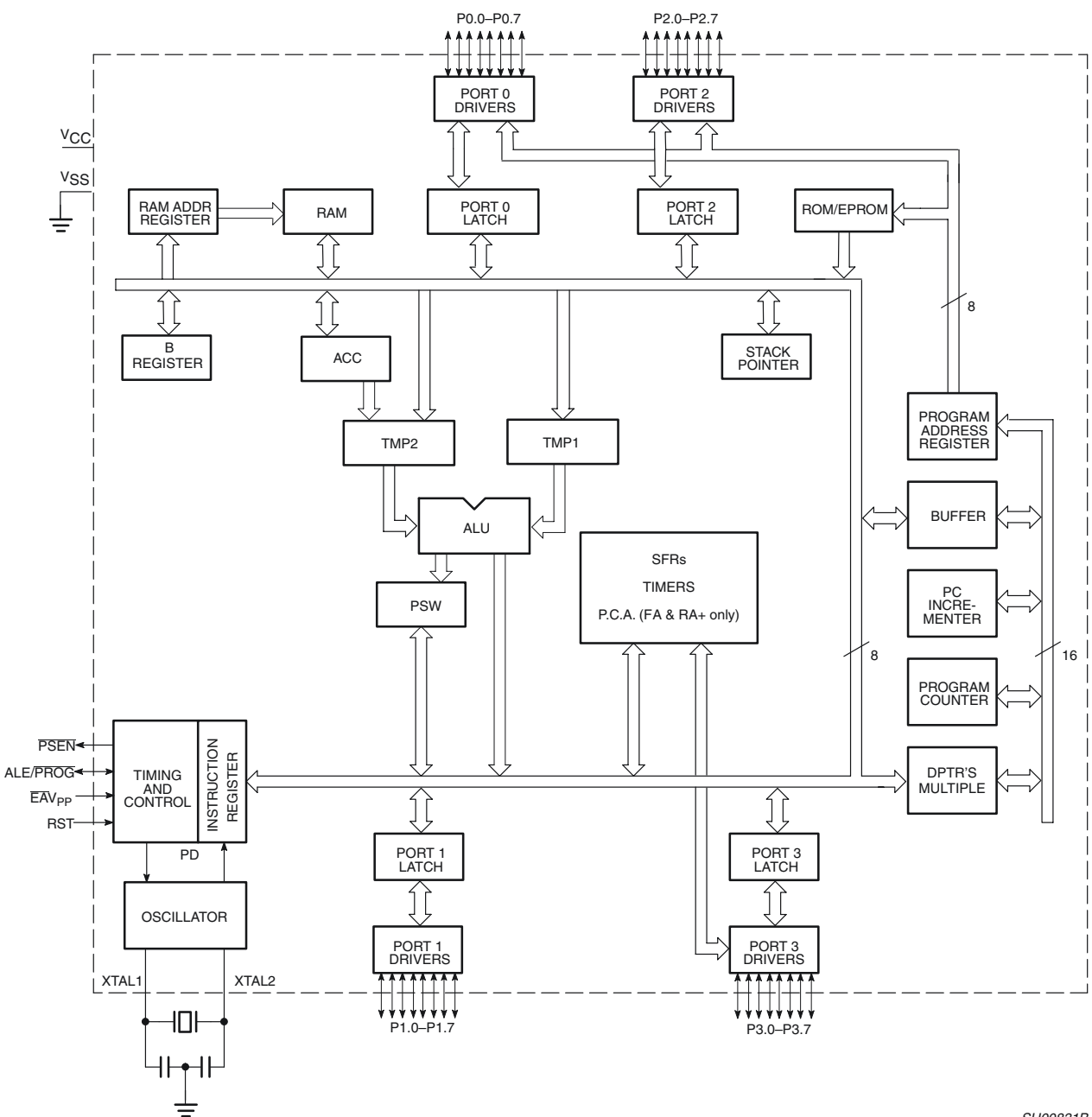

SU00831B

PINS DESCRIPTION OF IC P8XC54(8)SBBB

PIN FUNCTION

MNEMONIC	PIN NUMBER			TYPE	NAME AND FUNCTION
	DIP	LCC	QFP		
V _{SS}	20	22	16	I	Ground: 0 V reference.
V _{CC}	40	44	38	I	Power Supply: This is the power supply voltage for normal, idle, and power-down operation.
P0.0–P0.7	39–32	43–36	37–30	I/O	Port 0: Port 0 is an open-drain, bidirectional I/O port. Port 0 pins that have 1s written to them float and can be used as high-impedance inputs. Port 0 is also the multiplexed low-order address and data bus during accesses to external program and data memory. In this application, it uses strong internal pull-ups when emitting 1s. Port 0 also outputs the code bytes during program verification and received code bytes during EPROM programming. External pull-ups are required during program verification.
P1.0–P1.7	1–8	2–9	40–44, 1–3	I/O	Port 1: Port 1 is an 8-bit bidirectional I/O port with internal pull-ups. Port 1 pins that have 1s written to them are pulled high by the internal pull-ups and can be used as inputs. As inputs, port 1 pins that are externally pulled low will source current because of the internal pull-ups. (See DC Electrical Characteristics: I _{IL}). Port 1 also receives the low-order address byte during program memory verification. Alternate functions for 8XC51FX and 8XC51RX+ Port 1 include: T2 (P1.0): Timer/Counter 2 external count input/Clockout (see Programmable Clock-Out) T2EX (P1.1): Timer/Counter 2 Reload/Capture/Direction Control ECI (P1.2): External Clock Input to the PCA CEX0 (P1.3): Capture/Compare External I/O for PCA module 0 CEX1 (P1.4): Capture/Compare External I/O for PCA module 1 CEX2 (P1.5): Capture/Compare External I/O for PCA module 2 CEX3 (P1.6): Capture/Compare External I/O for PCA module 3 CEX4 (P1.7): Capture/Compare External I/O for PCA module 4
P2.0–P2.7	21–28	24–31	18–25	I/O	Port 2: Port 2 is an 8-bit bidirectional I/O port with internal pull-ups. Port 2 pins that have 1s written to them are pulled high by the internal pull-ups and can be used as inputs. As inputs, port 2 pins that are externally being pulled low will source current because of the internal pull-ups. (See DC Electrical Characteristics: I _{IL}). Port 2 emits the high-order address byte during fetches from external program memory and during accesses to external data memory that use 16-bit addresses (MOVX @DPTR). In this application, it uses strong internal pull-ups when emitting 1s. During accesses to external data memory that use 8-bit addresses (MOV @Ri), port 2 emits the contents of the P2 special function register. Some Port 2 pins receive the high order address bits during EPROM programming and verification.
P3.0–P3.7	10–17	11, 13–19	5, 7–13	I/O	Port 3: Port 3 is an 8-bit bidirectional I/O port with internal pull-ups. Port 3 pins that have 1s written to them are pulled high by the internal pull-ups and can be used as inputs. As inputs, port 3 pins that are externally being pulled low will source current because of the pull-ups. (See DC Electrical Characteristics: I _{IL}). Port 3 also serves the special features of the 80C51 family, as listed below: RxD (P3.0): Serial input port TxD (P3.1): Serial output port INT0 (P3.2): External interrupt INT1 (P3.3): External interrupt T0 (P3.4): Timer 0 external input T1 (P3.5): Timer 1 external input WR (P3.6): External data memory write strobe RD (P3.7): External data memory read strobe
RST	9	10	4	I	Reset: A high on this pin for two machine cycles while the oscillator is running, resets the device. An internal diffused resistor to V _{SS} permits a power-on reset using only an external capacitor to V _{CC} .
ALE/PROG	30	33	27	O	Address Latch Enable/Program Pulse: Output pulse for latching the low byte of the address during an access to external memory. In normal operation, ALE is emitted at a constant rate of 1/6 the oscillator frequency, and can be used for external timing or clocking. Note that one ALE pulse is skipped during each access to external data memory. This pin is also the program pulse input (PROG) during EPROM programming. ALE can be disabled by setting SFR auxiliary.0. With this bit set, ALE will be active only during a MOVX instruction.
PSEN	29	32	26	O	Program Store Enable: The read strobe to external program memory. When executing code from the external program memory, PSEN is activated twice each machine cycle, except that two PSEN activations are skipped during each access to external data memory. PSEN is not activated during fetches from internal program memory.
EAV _{PP}	31	35	29	I	External Access Enable/Programming Supply Voltage: EAV must be externally held low to enable the device to fetch code from external program memory locations starting with 0000H. If EAV is held high, the device executes from internal program memory unless the program counter contains an address greater than 8k Devices (1FFFH), 16k Devices (3FFFH) or 32k Devices (7FFFH). Since the RD+ has 64k Internal Memory, the RD+ will execute only from internal memory when EAV is held high. This pin also receives the 12.75 V programming supply voltage (V _{PP}) during EPROM programming. If security bit 1 is programmed, EAV will be internally latched on Reset.
XTAL1	19	21	15	I	Crystal 1: Input to the inverting oscillator amplifier and input to the internal clock generator circuits.
XTAL2	18	20	14	O	Crystal 2: Output from the inverting oscillator amplifier.

SET BLOCK DIAGRAM

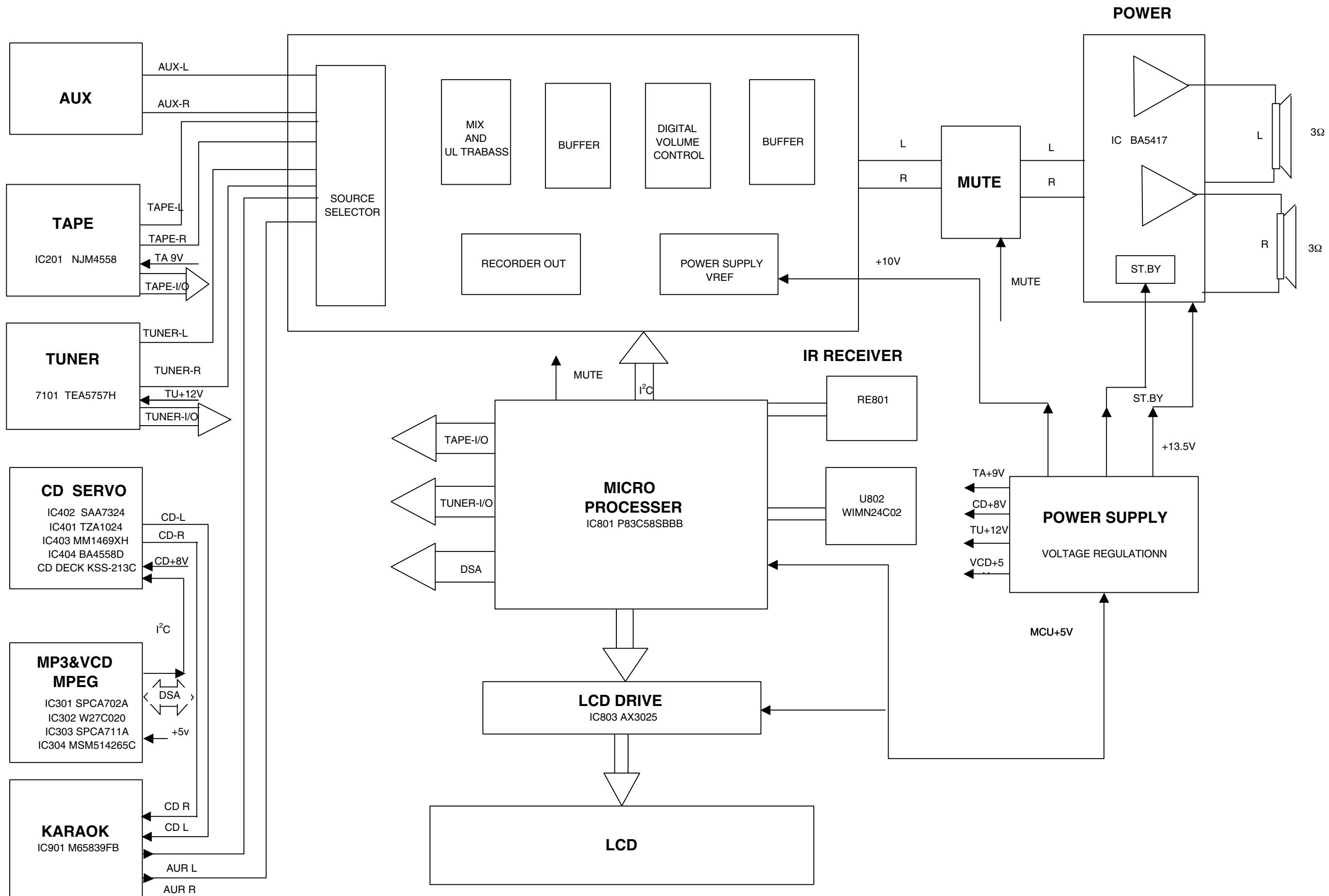

SET WIRING DIAGRAM

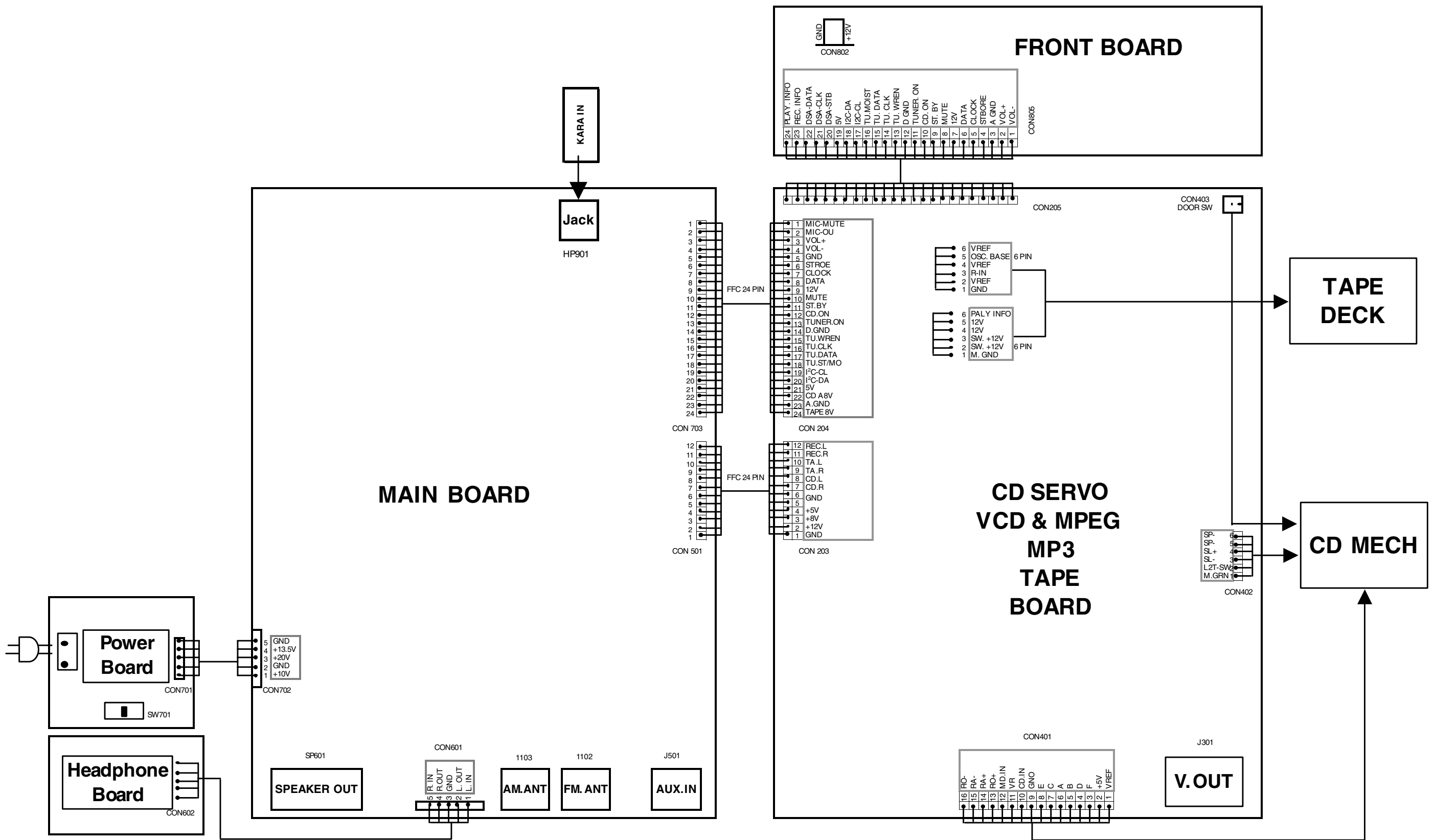

CIRCUIT DIAGRAM - LED BOARD

CON909 A1 R992 A3 R994 A3 R996 A3 LED802 A4 LED804 A4 LED806 A4
 R991 A3 R993 A3 R995 A3 LED801 A4 LED803 A4 LED805 A4

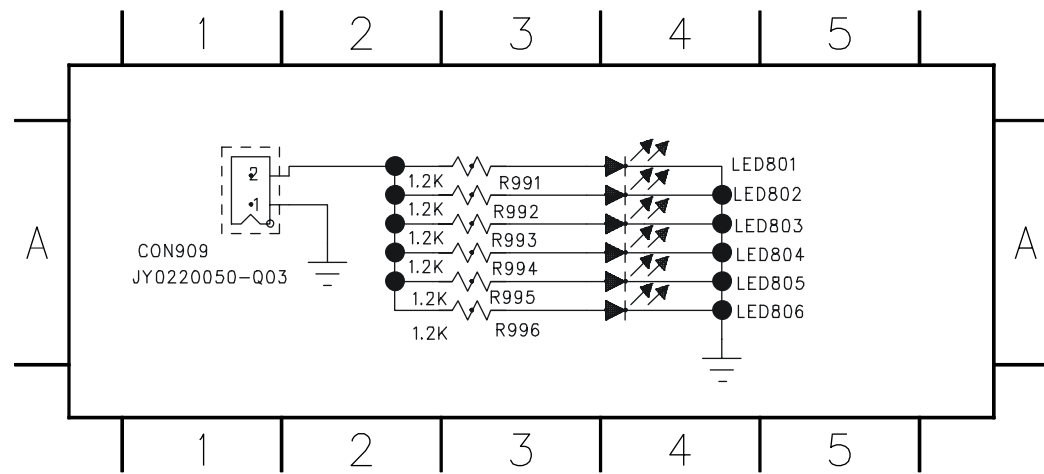

LAYOUT DIAGRAM - LED BOARD

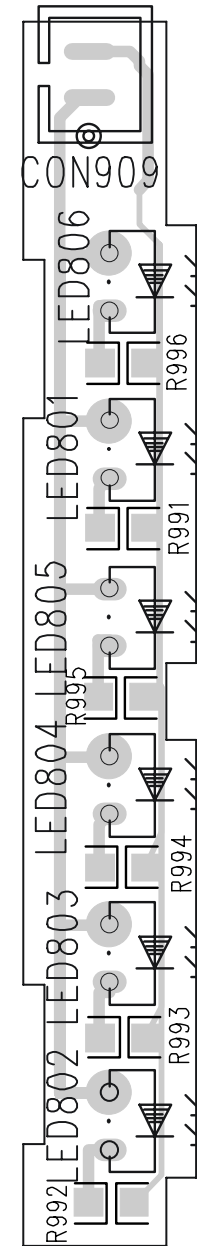

CIRCUIT DIAGRAM - POWER BOARD

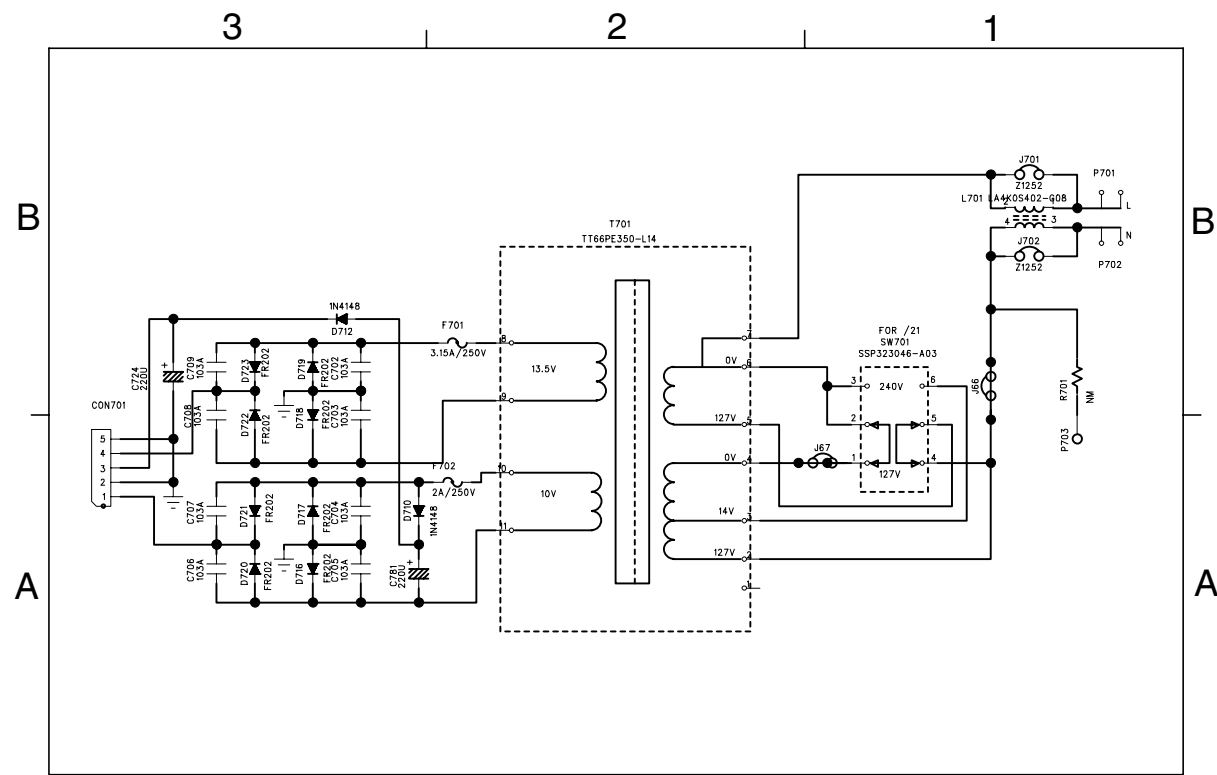

LAYOUT DIAGRAM - POWER BOARD

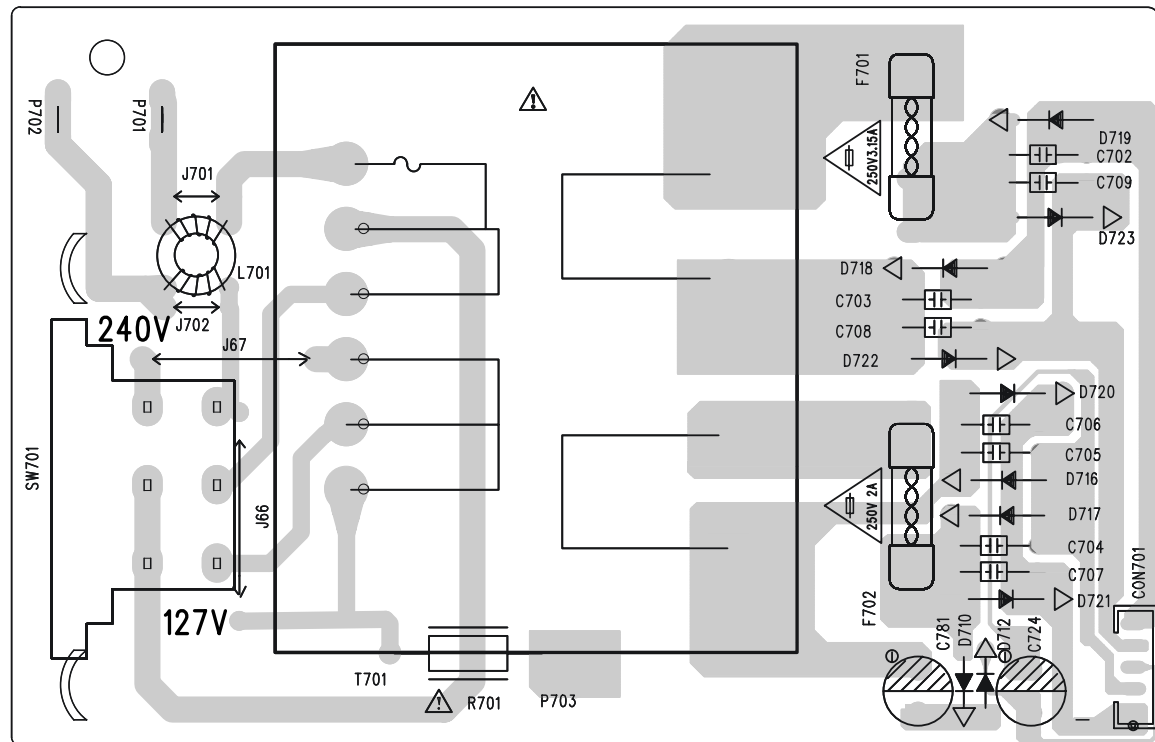

CIRCUIT DIAGRAM - HEADPHONE BOARD

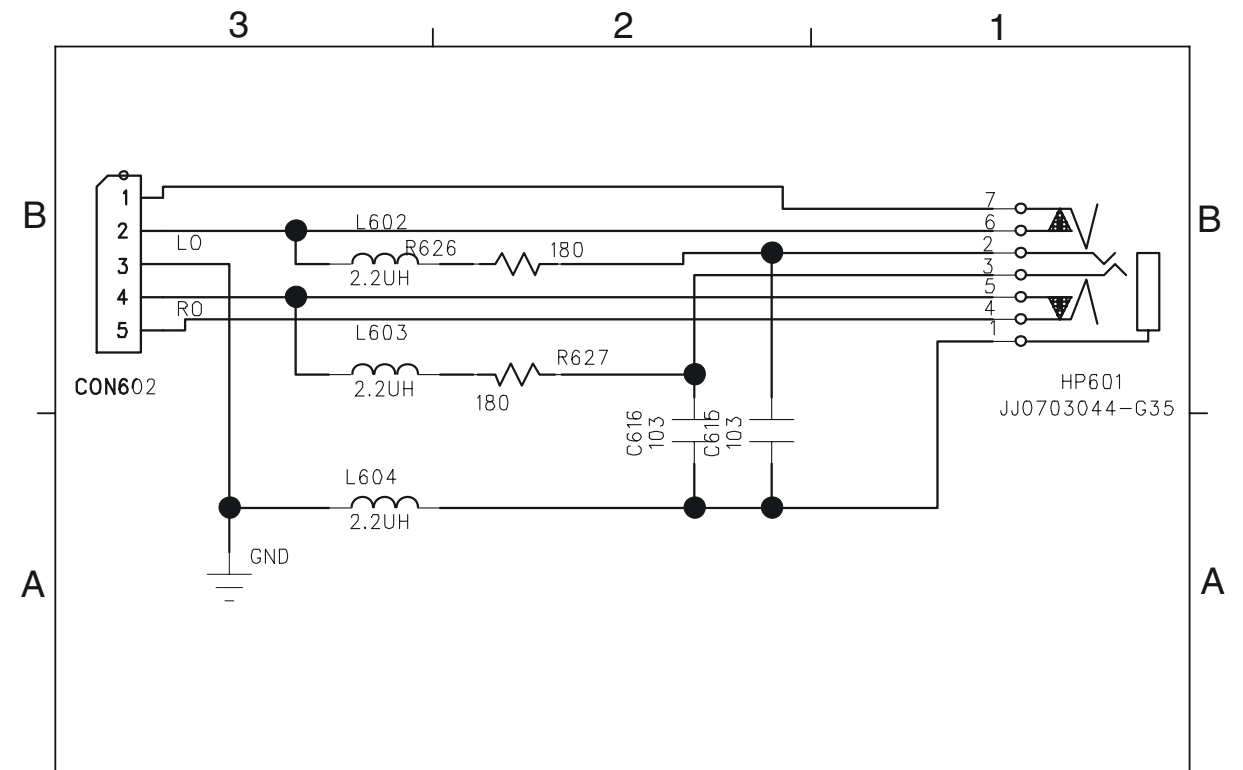

LAYOUT DIAGRAM - HEADPHONE BOARD

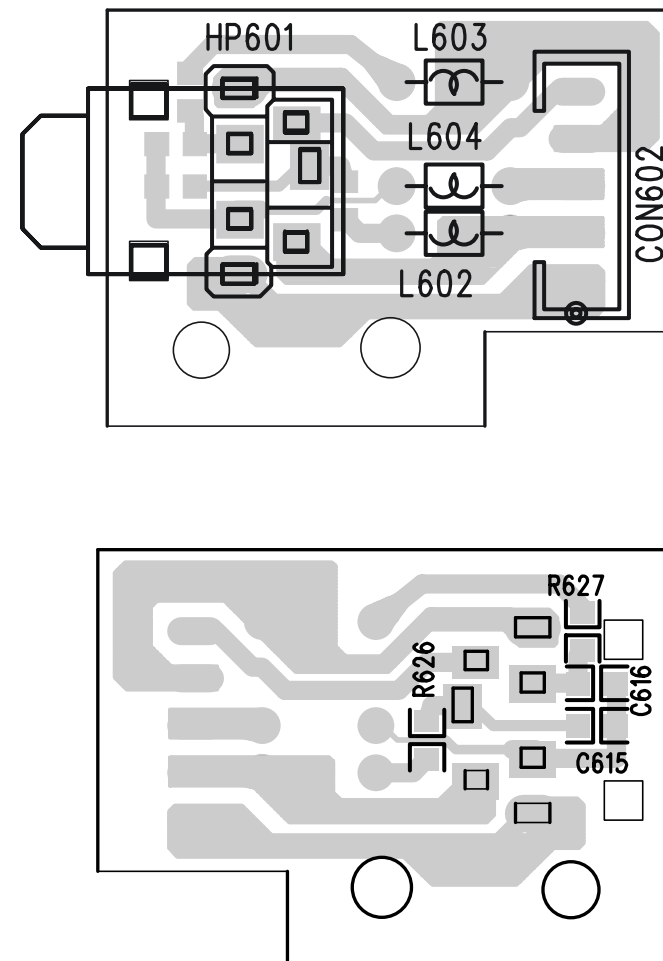

CIRCUIT DIAGRAM - VCD & TAPE BOARD (Part 1)

CD PART

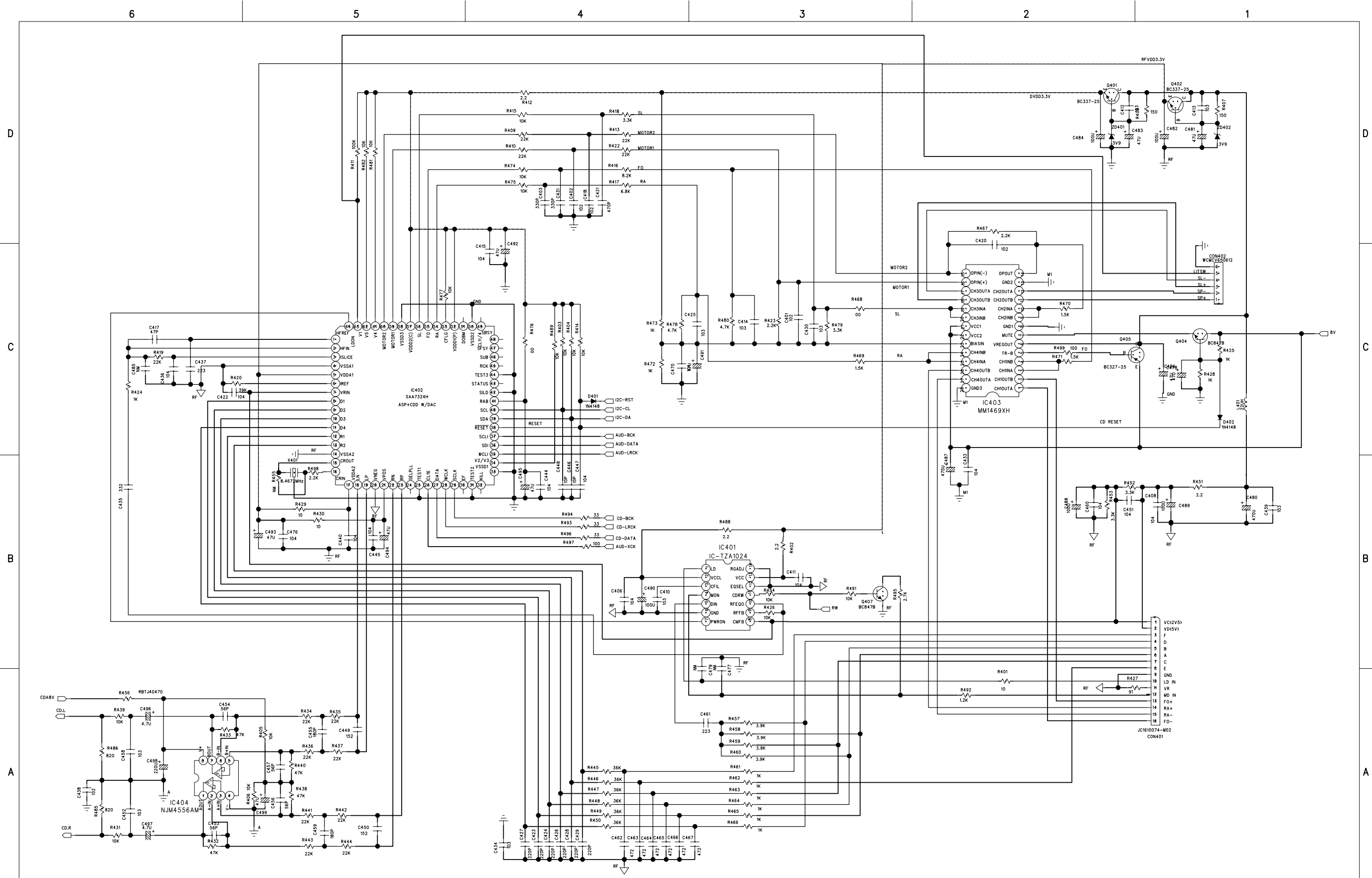

CIRCUIT DIAGRAM - VCD & TAPE BOARD (Part 2)

TAPE PART

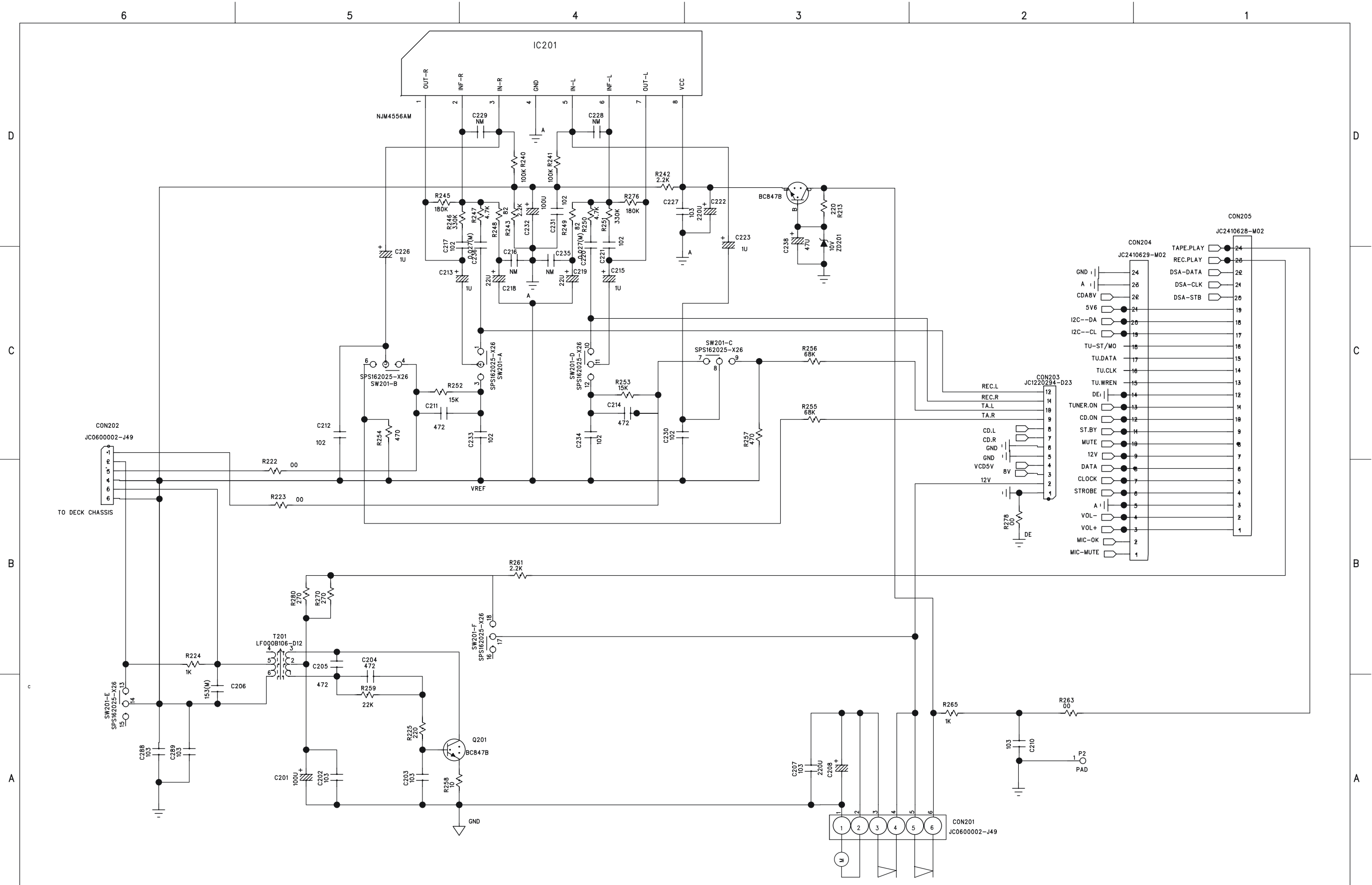

CIRCUIT DIAGRAM - VCD & TAPE BOARD (Part 3)

MPEG PART

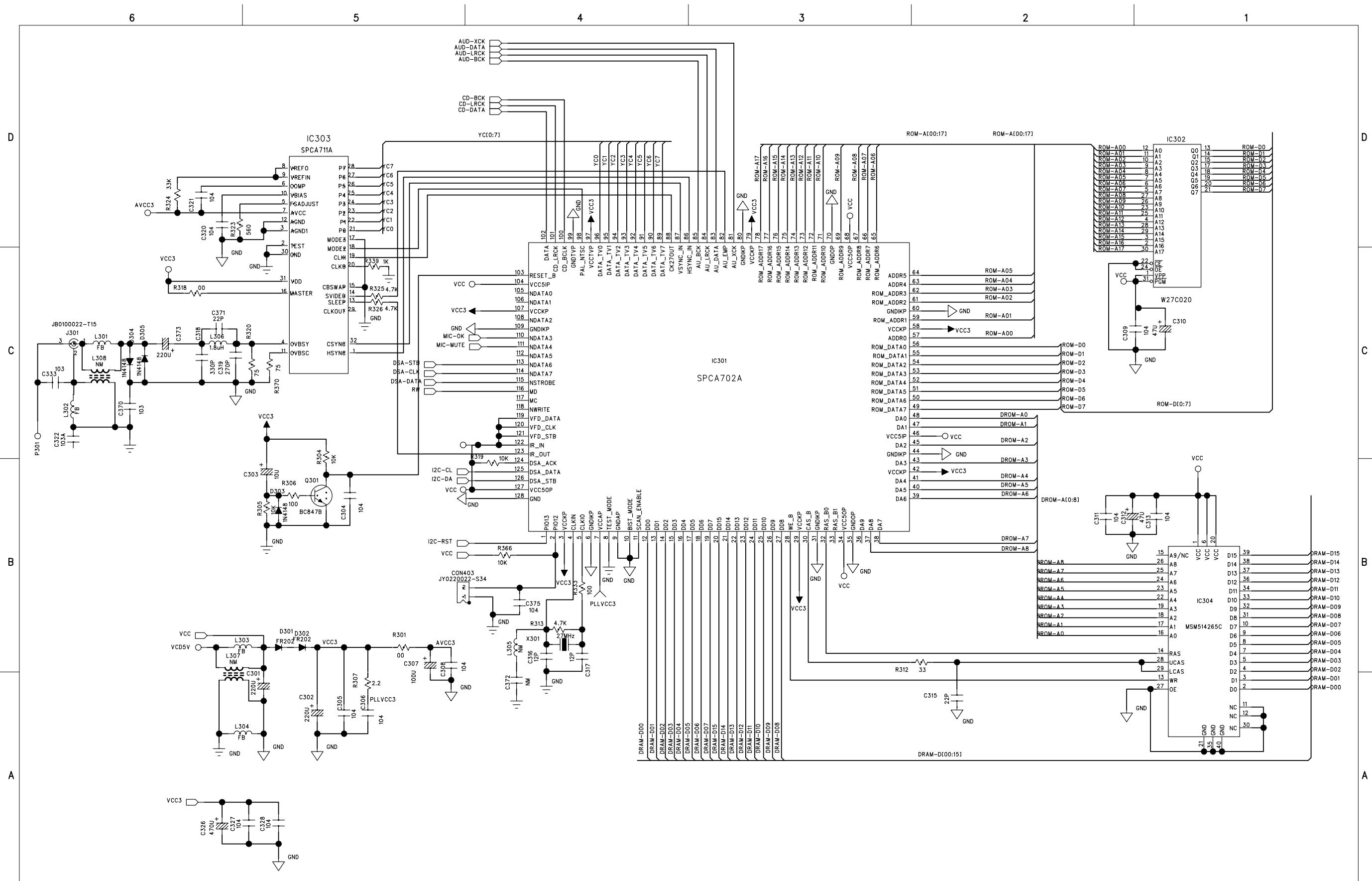

LAYOUT DIAGRAM - VCD & TAPE BOARD

COMPONENT SIDE

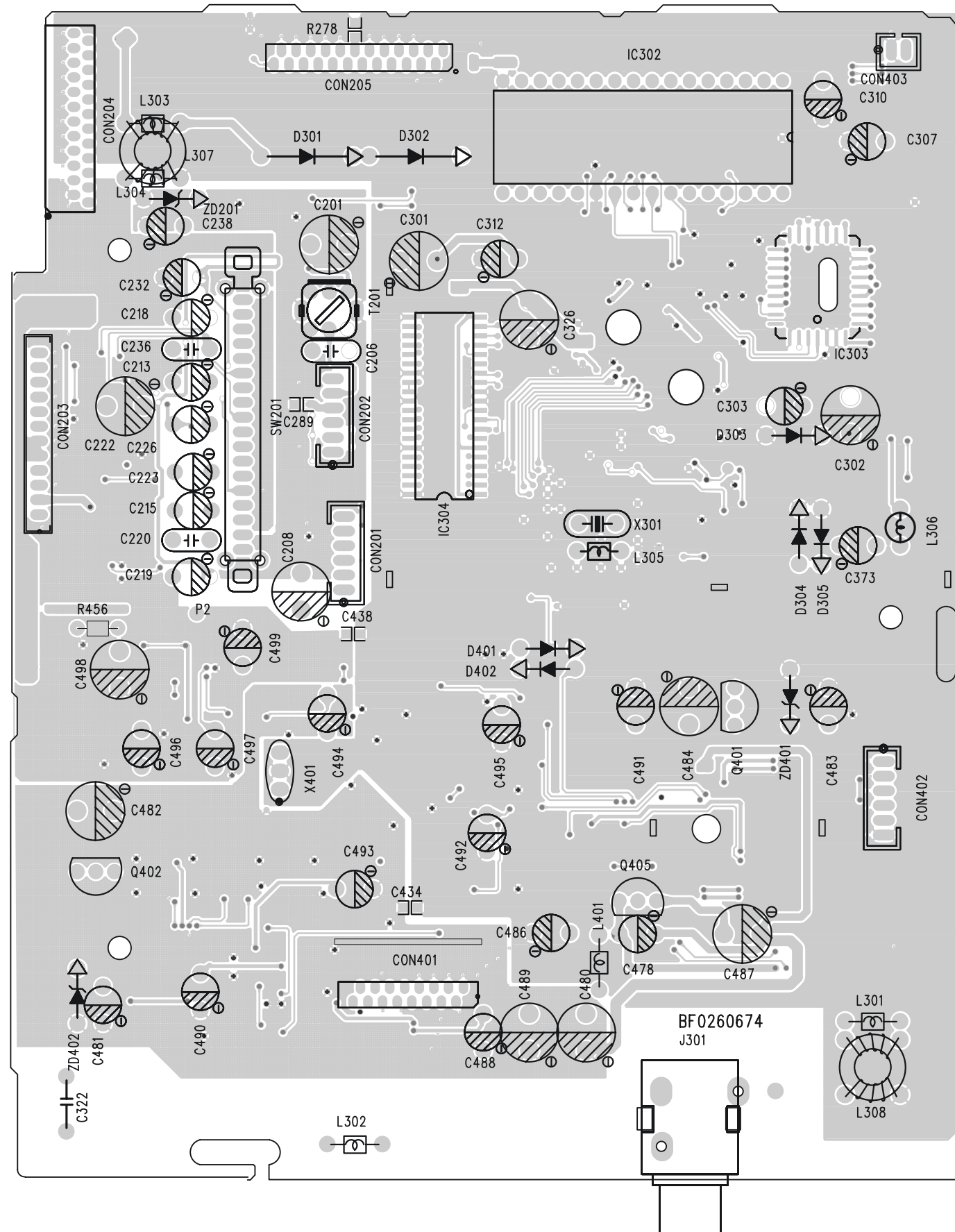

LAYOUT DIAGRAM - VCD & TAPE BOARD

SMD SIDE

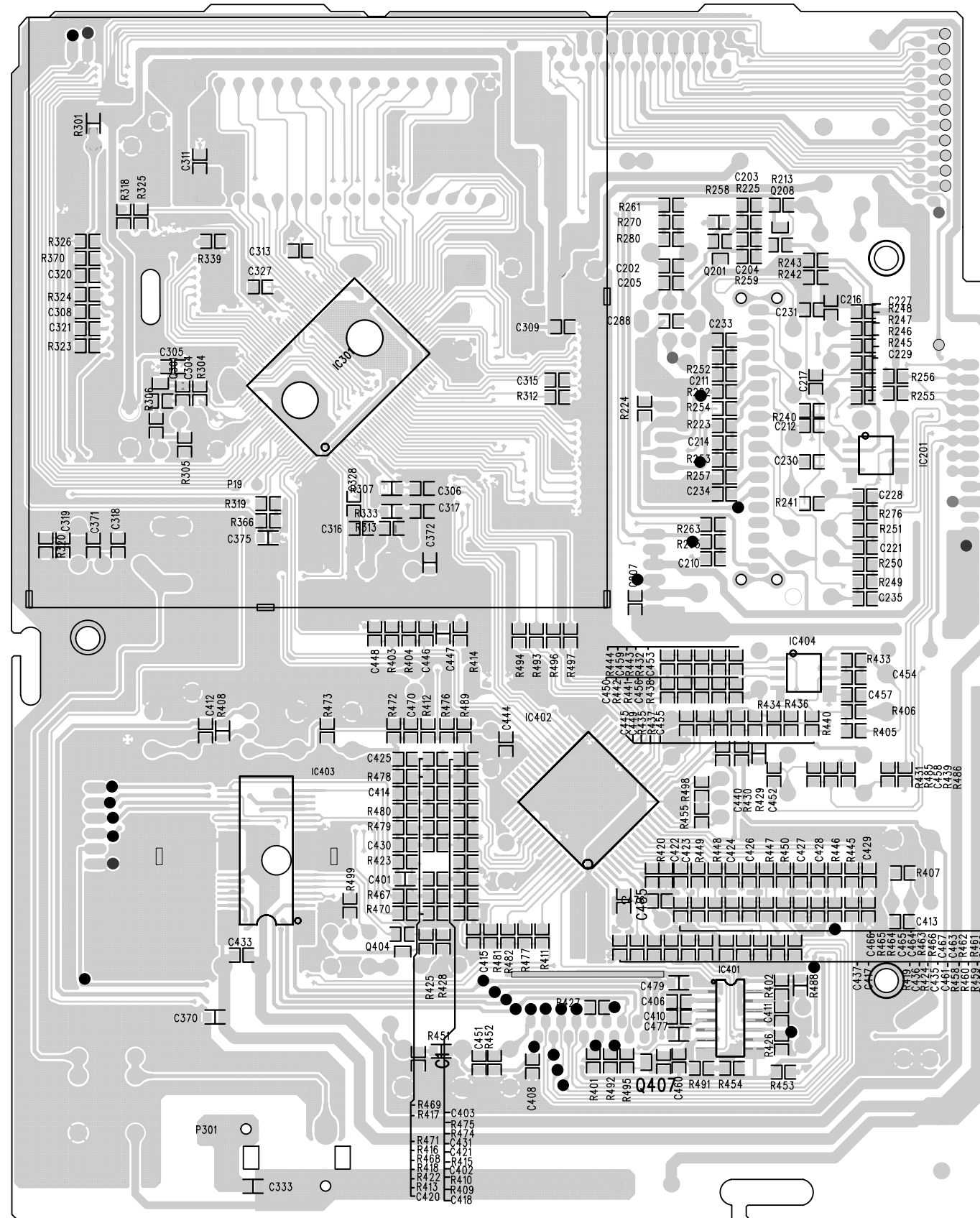

CIRCUIT DIAGRAM - FRONT BOARD

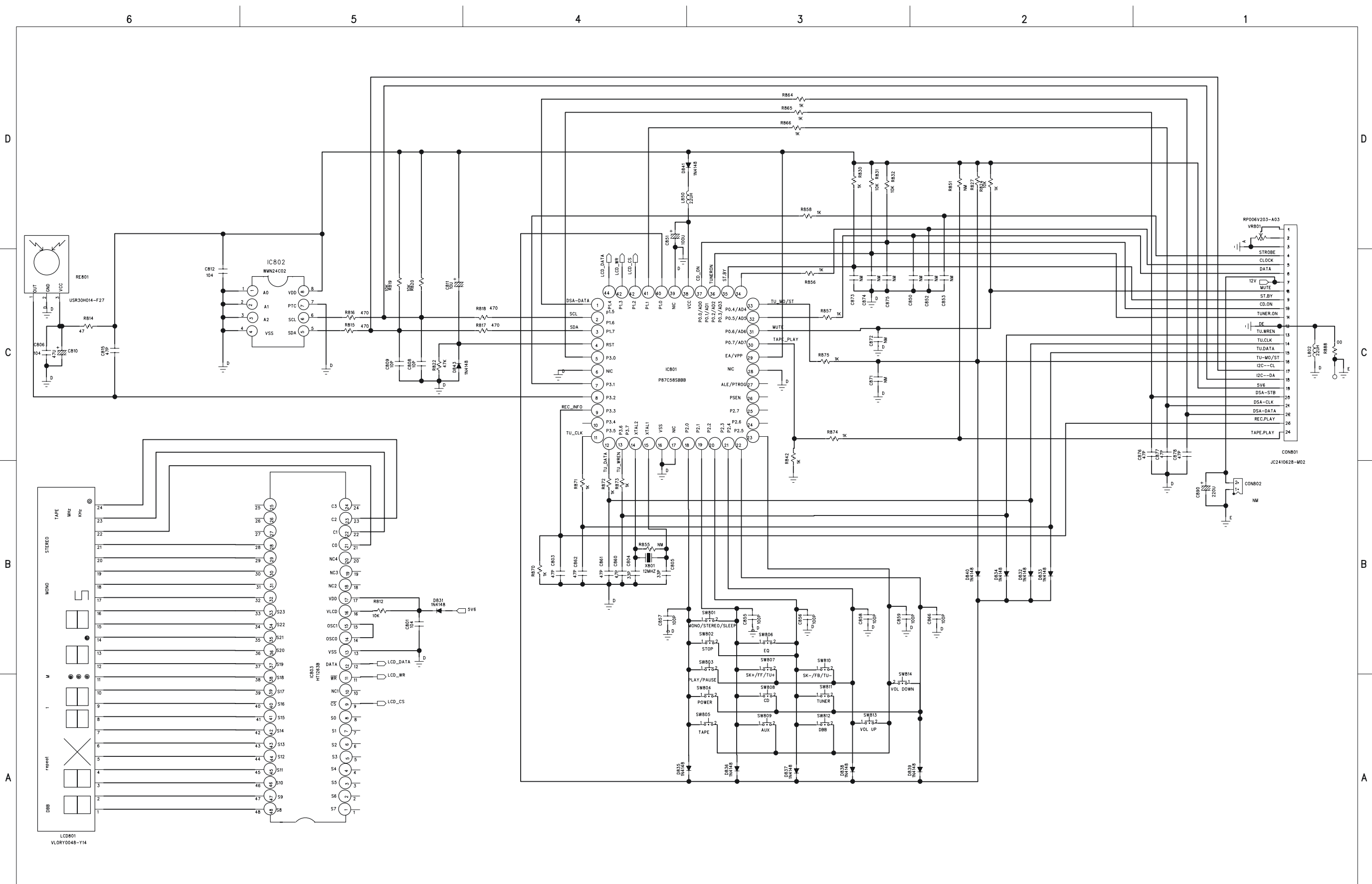

LAYOUT DIAGRAM - FRONT BOARD

COMPONENT SIDE

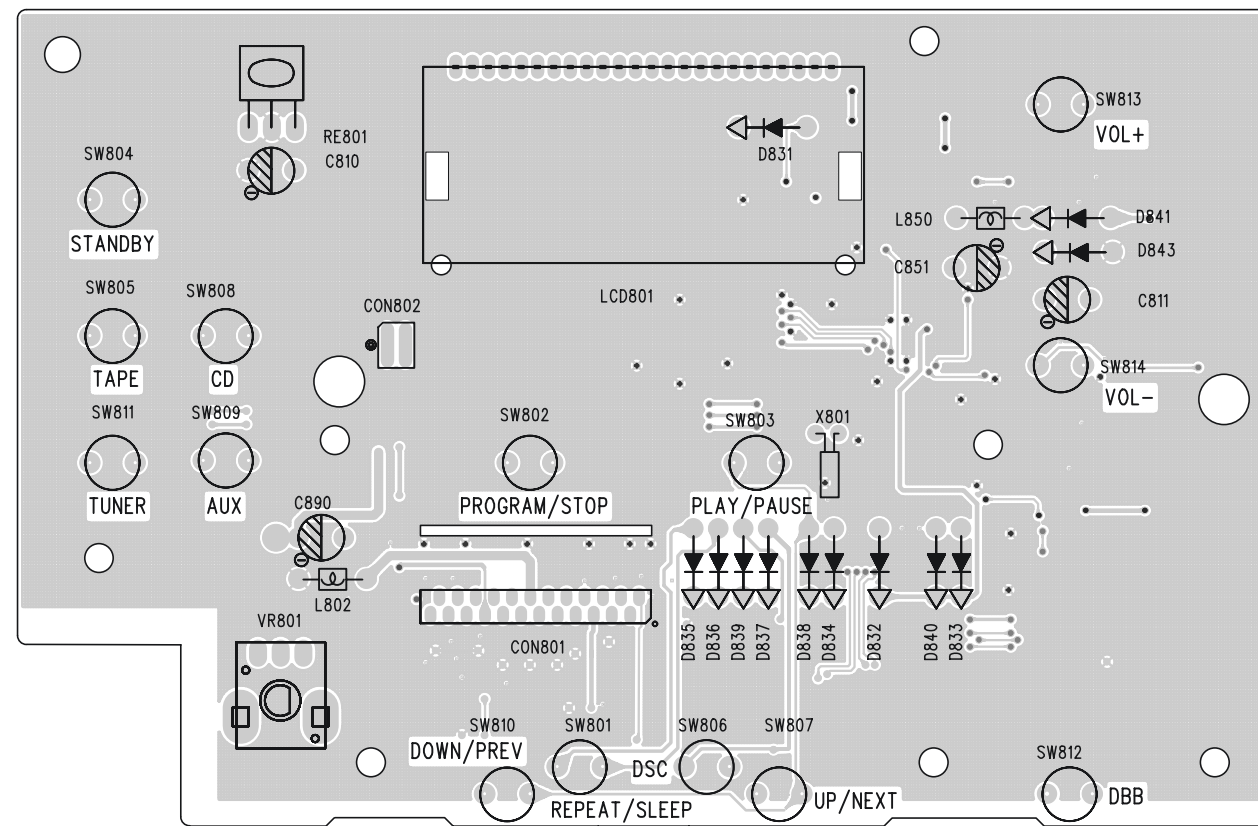

LAYOUT DIAGRAM - FRONT BOARD

SMD SIDE

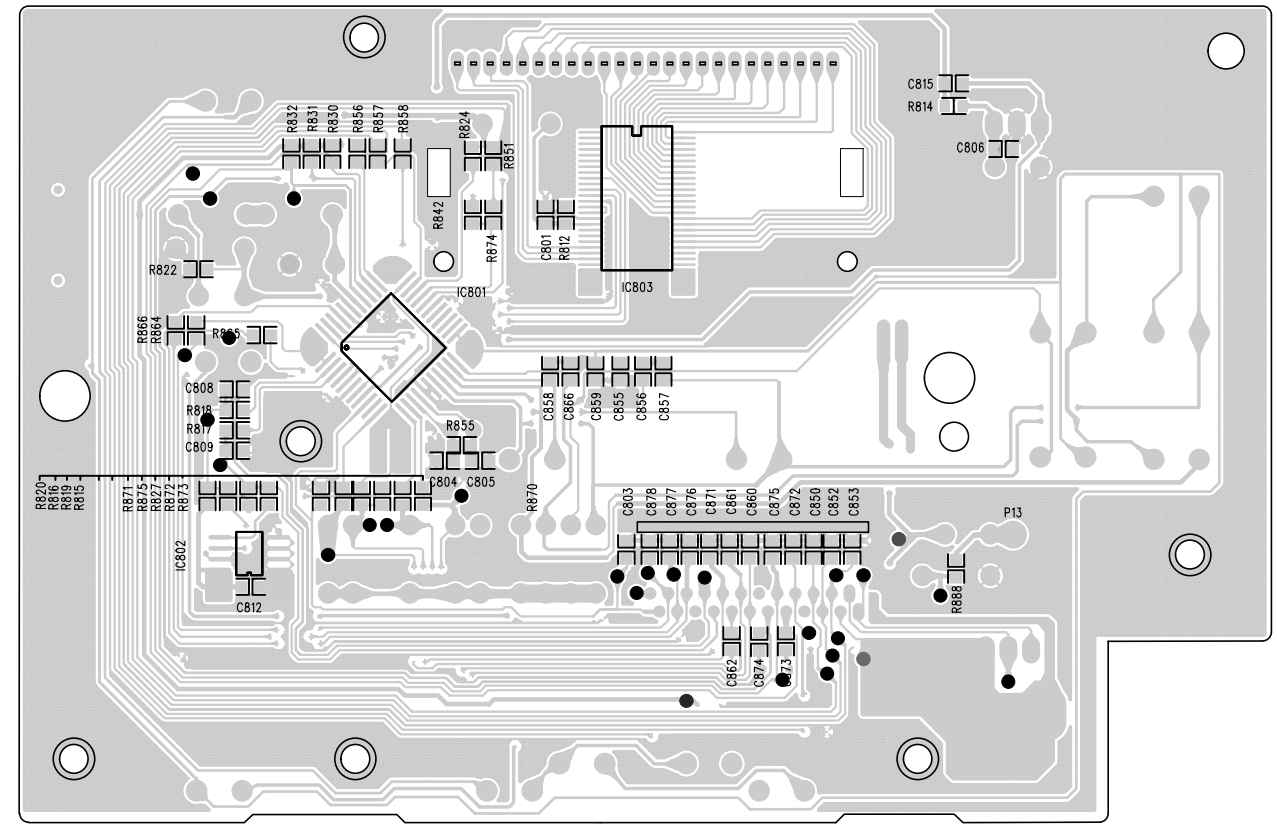

CIRCUIT DIAGRAM - MAIN BOARD (Part 1)

POWER AMPLIFIER PART

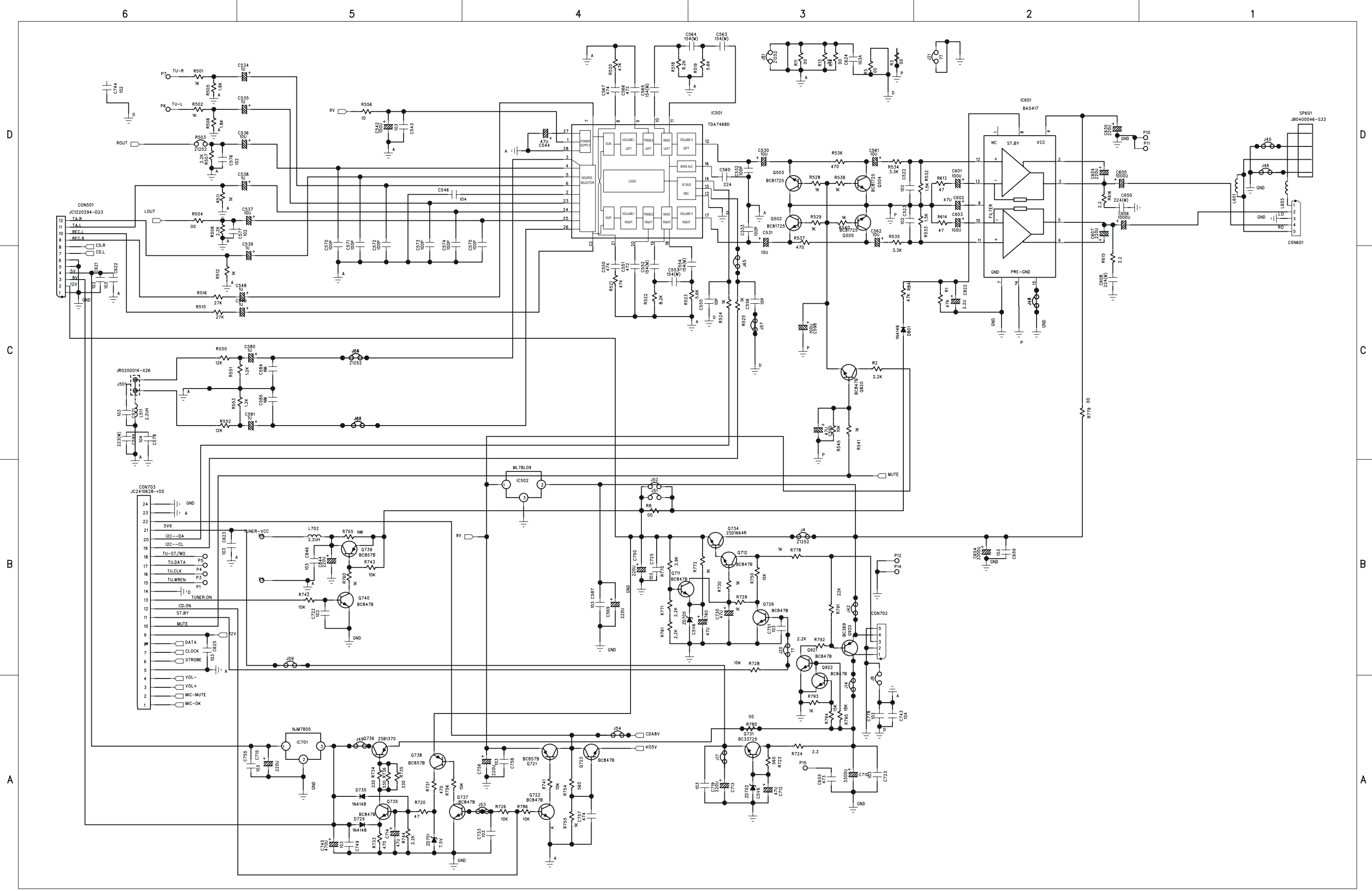

CIRCUIT DIAGRAM - MAIN BOARD (Part 2)

TUNER PART - ECO6 AS NON CENELEC

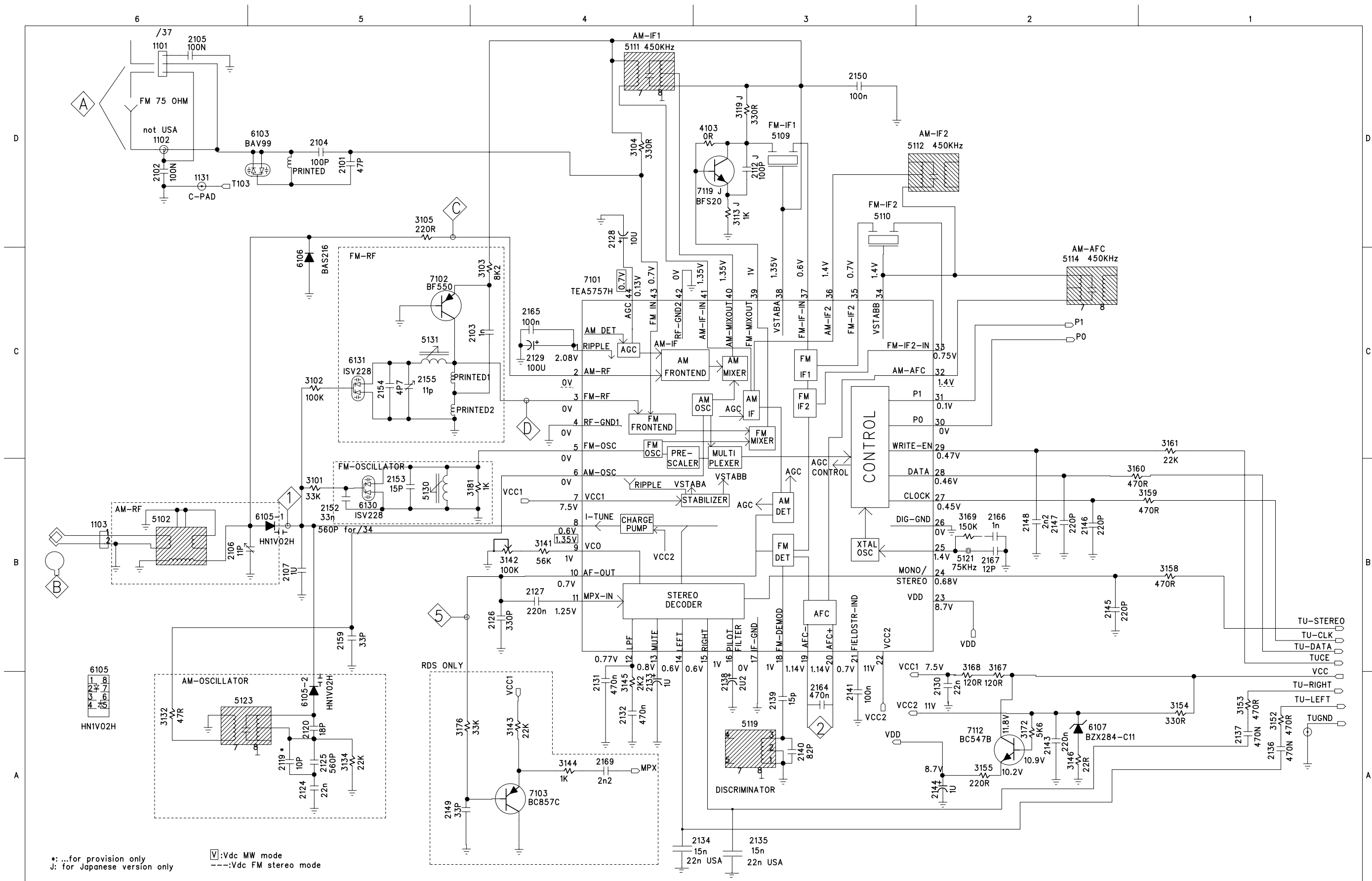

CIRCUIT DIAGRAM - MAIN BOARD (Part 3)

KARAOKE PART

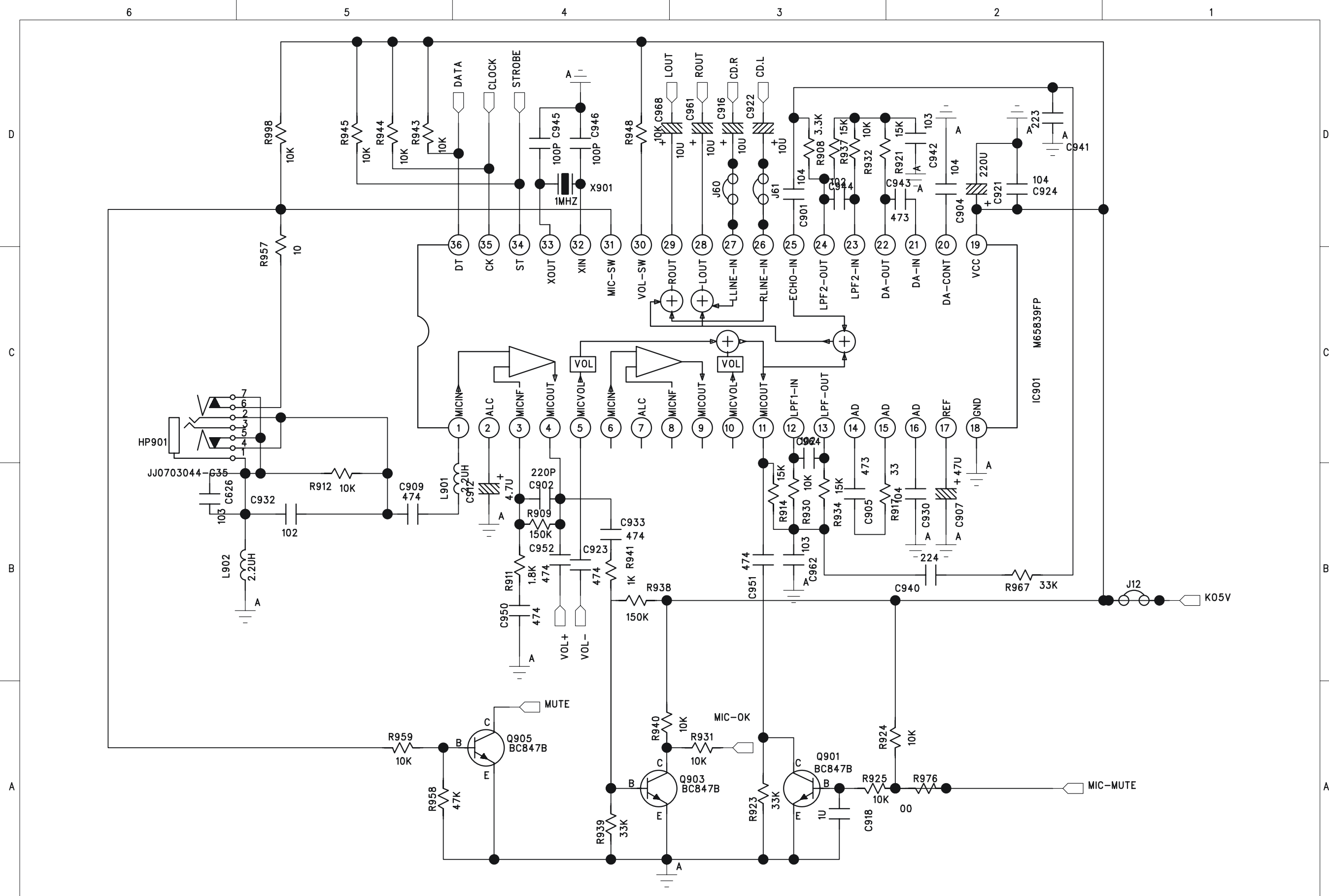

LAYOUT DIAGRAM - MAIN BOARD

COMPONENT SIDE

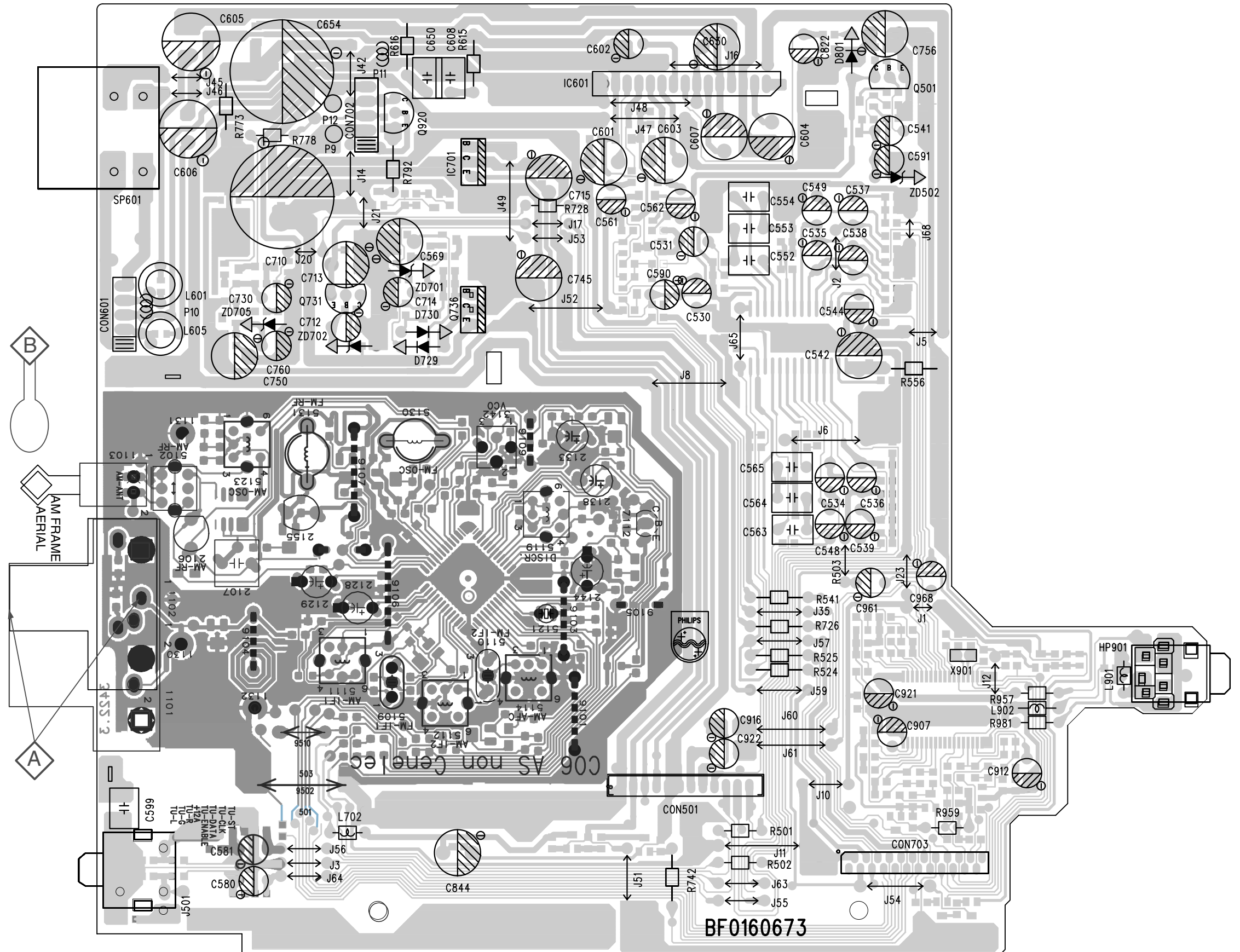

LAYOUT DIAGRAM - MAIN BOARD

SMD SIDE

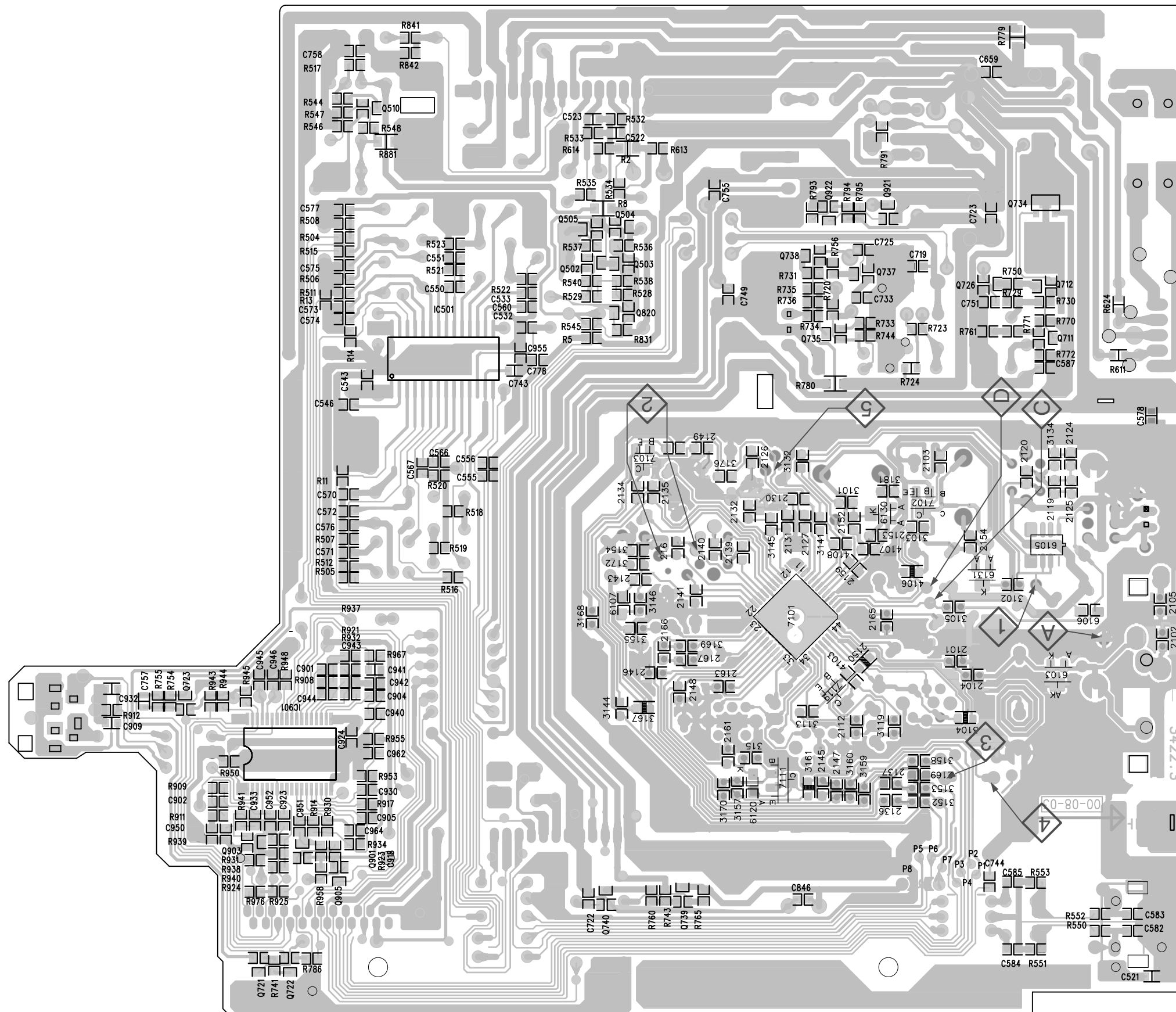

TUNER ADJUSTMENT TABLE (ECO6 FM/MW- and FM/MW/LW - versions with AM-frame aerial)

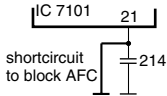
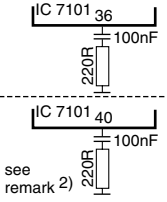
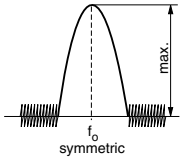
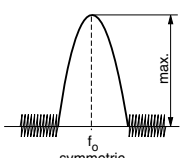
Waverange	Input frequency	Input	Tuned to	Adjust	Output	Scope/Voltmeter
VARICAP ALIGNMENT						
FM 87.5 - 108MHz (65.81 - 74, 87.5 - 108MHz)			108MHz	5130		8V -0.2V
			87.5MHz (65.81MHz)	check		4.3V -0.5V (1.2V -0.5V)
MW FM/AM-version, 10kHz grid 530 - 1700kHz			1700kHz	5123	1	8V -0.2V
			530kHz	check		1.1V -0.4V
FM/MW-version, 9kHz grid 531 - 1602kHz			1602kHz	5123		6.9V -0.2V
			531kHz	check		1.1V -0.4V
LW 153 - 279kHz			279kHz	5122		8V -0.2V
			153kHz	check		1.1V -0.4V
MW FM/MW/LW- version, 9kHz grid 531 - 1602kHz			1602kHz	5123	8V -0.2V	
			531kHz	check	1.1V -0.4V	
FM IF						
FM	10.7MHz, 45mV continuous wave	D		5119	2	0 - 3 mV DC
FM RF						
FM 87.5 - 108MHz (65.81 - 74, 87.5 - 108MHz)	108MHz	A	108MHz	2155	4	MAX
	87.5MHz (65.81MHz)	mod=1kHz Δf=-22.5kHz	87.5MHz (65.81MHz)	5131		
VCO						
FM	98MHz, 1mV continuous wave	A	98MHz	3142	3	152kHz -1kHz ¹⁾
AM IF						
MW	450kHz connect pin 6 of IC 7101 (AM Osc.) with 3.3kΩ to Vcc	C		5111	5	
			5112			
AM AFC		C		5114	2	0 - 2 mV DC
AM RF³⁾						
MW⁴⁾ FM/MW/LW- and FM/MW-version (9kHz grid) 531 - 1602kHz	1494kHz	B	1494kHz	2106	5	
	558kHz		558kHz	5102		
LW	198kHz		198kHz	5103		
MW FM/AM-version, 10kHz grid 530 - 1700kHz	1500kHz		Δf = -30kHz V _{RF} as low as possible	1500kHz		
	560kHz	560kHz	5102			

Use Service Testprogram. By selecting the TUNER TEST test frequencies will be stored as preset frequencies automatically.

1) If sensitivity of frequency counter is too low adjust to max. channel separation (input signal: stereo left 90% + 9%, adjust output on right channel to minimum)
2) RC network serves for damping the IF-filter while adjusting the other one.

TAPE ADJUSTMENT & CHECK TABLE

	TEST CASSETTE	RECORDER MODE	MEASURE ON	READ ON	ADJUST	
					with	to
MOTOR SPEED	SBC420 3150Hz	PLAY		frequency counter	check	3150Hz +/- 2%
WOW & FLUTTER	SBC420 3150Hz	PLAY	1 or 2 LEFT RIGHT	W&F-meter	check	< 0.4 % DIN
ADJUST AZIMUTH	SBC420 10kHz	PLAY FWD PLAY REV ^		mV-meter	left hand screw right hand screw	max. output level & left=right
PLAYBACK LEVEL & FREQ. RESPONSE	SBC420 315Hz	PLAY		mV-meter	check	125mV +/- 3dB (see fig.1 for freq. response)
CHECK RECORD/PLAYBACK FREQUENCY AND DISTORTION						
Inject 3mV signals 100Hz, 250Hz, 1kHz, 10kHz, 12.5kHz via 3 or 4	SBC419A or SBC420	RECORD				
	RECORDED CASSETTE	PLAY	1 or 2 LEFT RIGHT	mV-meter	check	limits see fig. 2 *
Inject 1kHz 8.85mV via 3 or 4	SBC419A or SBC420	RECORD				
	RECORDED CASSETTE	PLAY	1 or 2 LEFT RIGHT	THD-meter	check	< 3% *

SBC419A : 4822 397 30069
SBC420 : 4822 397 30071

^ For Auto-reverse version only
* If high frequencies are not within limits, decrease bias and re-measure. If distortion is too high, increase bias and re-measure

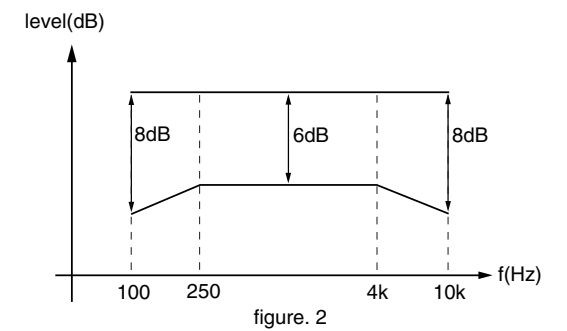
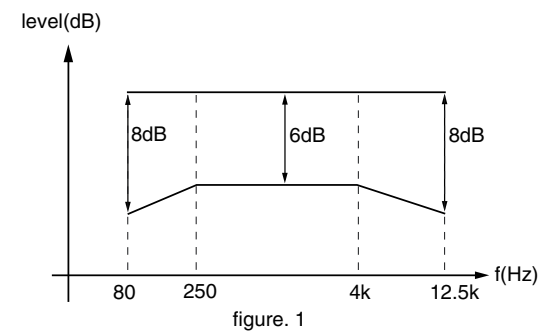

EXPLODED VIEW DIAGRAM

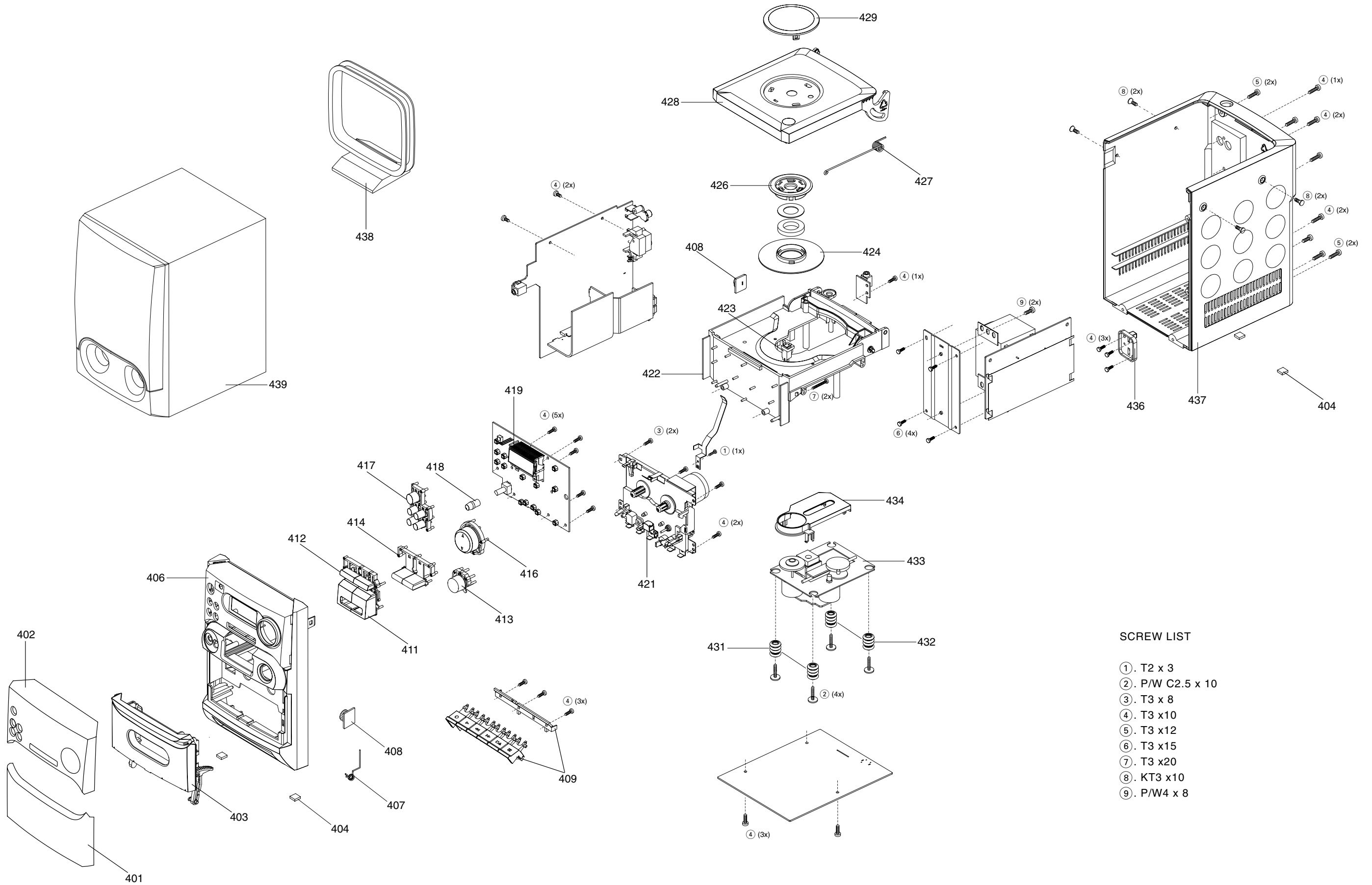

SCREW LIST

- ①. T2 x 3
- ②. P/W C2.5 x 10
- ③. T3 x 8
- ④. T3 x10
- ⑤. T3 x12
- ⑥. T3 x15
- ⑦. T3 x20
- ⑧. KT3 x10
- ⑨. P/W4 x 8

MECHANICAL PARTSLIST**ACCESSORIES**

401	9965 000 14686	CABINET LENS		9965 000 14696	REMOTE CONTROL MC-V65
402	9965 000 14687	DISPLAY WINDOW	438	4822 303 50082	AM LOOP ANTENNA
403	9965 000 14475	CASS DOOR		9965 000 111 57	FM ANTENNA WIRE
404	9965 000 111 86	FOOT RUBBER (SQ)	439	9965 000 14697	SPEAKER BOX ASSY MC-V65
406	9965 000 14683	FRONT CABINET			
407	9965 000 14490	CASSETTE SPRING			
408	4822 529 10322	DAMPER ASSY			
409	9965 000 14688	CASS KEY			
411	9965 000 14483	SEARCH CD BUTTON			
412	9965 000 14691	PLAY CD BUTTON			
413	9965 000 14690	DBB BUTTON			
414	9965 000 14692	REPEAT BUTTON			
416	9965 000 14482	VOLUME BUTTON			
417	9965 000 14694	VOL MIC BUTTON			
418	9965 000 14486	POWER BUTTON			
419	9965 000 14499	LCD HOLDER			
421	9965 000 14497	CASS DECK TM-29PCF-01A			
422	9965 000 14689	CD TRAY			
423	9965 000 14498	PUSH LOCK SWITCH			
424	9965 000 14492	CHUCK BASE			
426	9965 000 14493	CHUCK HOLDER			
427	9965 000 14695	CD SPRING			
428	9965 000 14685	CD DOOR			
429	9965 000 14693	CD PANEL			
431	4822 529 10387	DAMPER - RUBBER (40 DEG)			
432	4822 529 10386	DAMPER - RUBBER (30 DEG)			
433	9965 000 14472	CD MECH KSM-213CDM			
434	9965 000 14489	CD COVER			
436	9965 000 14487	AC CORD COVER			
437	9965 000 14684	REAR CABINET			

Note: Only these parts mentioned in the list are normal service parts.

ELECTRICAL PARTS LIST**- MISCELLANEOUS -**

1101	9965 000 11393	FM ANTENNA TERMINAL 2P
CON201	9965 000 14698	CONNECTOR BASE 6P
CON202	9965 000 14698	CONNECTOR BASE 6P
CON203	9965 000 14699	CONN 12P TUC-P12X-31
CON204	9965 000 14700	FFC BASE 24PIN H
CON205	9965 000 14510	CON FFC BASE 1.0 24P
CON401	9965 000 14507	FFC CONNECTOR 16P
CON402	9965 000 14701	CONN ASSY 6P 2.0 120 PH
CON403	9965 000 14512	CONNECTOR BASE 2P V
CON501	9965 000 14699	CONN 12P TUC-P12X-31
CON601	9965 000 14702	CON ASSY 5P 2.5 160MM
CON702	9965 000 14703	CON ASSY 5P 2.5 200MM
CON703	9965 000 14510	CON FFC BASE 1.0 24P
CON801	9965 000 14700	FFC BASE 24PIN H
CON909	9965 000 14704	CONNECTOR 2P 2.0
F701	△4822 070 13152	FUSE 217 3.15A
F702	△4822 070 32002	FUSE 218 2A
HP601	9965 000 14524	HEADPHONE JACK
HP901	9965 000 14524	HEADPHONE JACK
J301	9965 000 14705	JACK PIN 1P YEL W/O SW
J501	9965 000 14706	RCA PIN JACK 2P V
LCD801	9965 000 14500	LCD
P09	9965 000 14707	CABLE SMF 1P/180/1P
P12	9965 000 14708	CABLE SRA 1P/200/1P
SP301	9965 000 14709	TERMINAL PIN
SP601	9965 000 14525	TERMINAL SP 4P
SW201	9965 000 11378	SWITCH SLIDE 6P2T
SW701	△9965 000 11348	VOLTAGE SELEC TOR 2P 5A
SW801	4822 276 13775	SWITCH
SW802	4822 276 13775	SWITCH
SW803	4822 276 13775	SWITCH
SW804	4822 276 13775	SWITCH
SW805	4822 276 13775	SWITCH
SW806	4822 276 13775	SWITCH
SW807	4822 276 13775	SWITCH
SW808	4822 276 13775	SWITCH
SW809	4822 276 13775	SWITCH
SW810	4822 276 13775	SWITCH
SW811	4822 276 13775	SWITCH
SW812	4822 276 13775	SWITCH
SW813	4822 276 13775	SWITCH
SW814	4822 276 13775	SWITCH
T701	△9965 000 14711	TRANSFORMER 127V/240V
	△9965 000 14712	MAINS CORD IEC
	9965 000 14713	CONN ASSY 6P 2.0 235/315MM
	9965 000 14714	CONN ASSY 6P 2.0 230 R PH
	9965 000 14715	FFC CABLE 1.0 100MM
	9965 000 14716	FFC CABLE 1.0 70MM
	9965 000 14717	CONN ASSY 2P 2.0 120 PH
	9965 000 14718	FF-CABLE 16P CD-RF

- CAPACITORS -

2106	9965 000 11368	CER TRIMMER 3P-11P 100V
2155	9965 000 11368	CER TRIMMER 3P-11P 100V

- RESISTORS -

3142	9965 000 11363	TRIM-POT CAR LIN 100K H
R615	△9965 000 14719	RES FUSE 2.2R 1/4W
R616	△9965 000 14719	RES FUSE 2.2R 1/4W
R773	△9965 000 14537	1/2W 1R

- COILS & FILTERS -

5102	9965 000 11354	MW RF COIL
5109	9965 000 11355	CER FILTER SFE 10,7MS3AZ
5110	9965 000 11355	CER FILTER SFE 10,7MS3AZ
5111	2422 549 44023	IND VAR 7MM 7PY 450KHZ
5112	4822 157 70302	F7MCS-12216N
5114	4822 157 70302	F7MCS-12216N
5119	4822 157 11443	2μ4 10M7
5121	9965 000 14720	X'TAL 75KHZ
5123	9965 000 11360	IND VAR 7MM 7PY 796 KHZ
5130	4822 157 11843	MD7B-01F
5131	4822 157 11843	MD7B-01F
L201	9965 000 11376	IND VAR 7MM 7PA 100KH Z B
L301	9965 000 14721	FILTER EMI BL01 RN1
L302	9965 000 14721	FILTER EMI BL01 RN1
L303	9965 000 14721	FILTER EMI BL01 RN1
L304	9965 000 14721	FILTER EMI BL01 RN1
L305	9965 000 14722	FIXED A 02 22μ TP 26MM
L306	9965 000 14723	COIL 2.2μH K FLR50
L401	9965 000 14722	FIXED A 02 22μ TP 26MM
L601	9965 000 14724	SPRING COIL 1.0μH K
L605	9965 000 14724	SPRING COIL 1.0μH K
L701	△9965 000 11379	FILTER MAINS 400μH
L802	9965 000 14722	FIXED A 02 22μ TP 26MM
L850	9965 000 14722	FIXED A 02 22μ TP 26MM
T201	9965 000 11376	IND VAR 7MM 7PA 100KH Z B
VR801	9965 000 14725	POTM CAR LIN 20K
X301	9965 000 14726	VIB XTAL 27MHZ 50PPM
X401	9965 000 14542	8MHZ 467 CST8.46 MTW A
X801	9965 000 14541	X-CRYSTAL 12M
X901	9965 000 14727	CERA RESONATOR 1MHZ

- DIODES -

6103	9965 000 11218	CHIP DIODE BAV99LT 1
6105	4822 130 83075	HN1V02H-B
6106	9340 255 30135	BAS216

ELECTRICAL PARTS LIST**- DIODES -**

6107	9340 386 90115	BZX284-C11
6120	9340 255 30135	BAS216
6130	4822 130 82833	1SV228
6131	4822 130 82833	1SV228
7102	4822 130 42131	BF550
7112	4822 130 40959	BC547B
D301	4822 130 83883	FR202
D302	4822 130 83883	FR202
D303	4822 130 30621	1N4148
D304	4822 130 30621	1N4148
D305	4822 130 30621	1N4148
D401	4822 130 30621	1N4148
D402	4822 130 30621	1N4148
D710	4822 130 30621	1N4148
D712	4822 130 30621	1N4148
D716	4822 130 83883	FR202
D717	4822 130 83883	FR202
D718	4822 130 83883	FR202
D719	4822 130 83883	FR202
D720	4822 130 83883	FR202
D721	4822 130 83883	FR202
D722	4822 130 83883	FR202
D723	4822 130 83883	FR202
D729	4822 130 30621	1N4148
D730	4822 130 30621	1N4148
D801	4822 130 30621	1N4148
D831	4822 130 30621	1N4148
D832	4822 130 30621	1N4148
D833	4822 130 30621	1N4148
D834	4822 130 30621	1N4148
D835	4822 130 30621	1N4148
D836	4822 130 30621	1N4148
D837	4822 130 30621	1N4148
D838	4822 130 30621	1N4148
D839	4822 130 30621	1N4148
D840	4822 130 30621	1N4148
D841	4822 130 30621	1N4148
D843	4822 130 30621	1N4148
LED801	9965 000 14543	LED HL-30105Q2AT
LED802	9965 000 14543	LED HL-30105Q2AT
LED803	9965 000 14543	LED HL-30105Q2AT
LED804	9965 000 14543	LED HL-30105Q2AT
LED805	9965 000 14543	LED HL-30105Q2AT
LED806	9965 000 14543	LED HL-30105Q2AT
ZD201	4822 130 61219	BZX79-B10
ZD401	4822 130 31981	BZX79-B3V9
ZD402	4822 130 31981	BZX79-B3V9
ZD502	4822 130 34173	BZX79-C5V6
ZD701	4822 130 80272	MTZJ7.5C
ZD702	4822 130 34173	BZX79-C5V6

- DIODES -

ZD705 4822 130 34173 BZX79-C5V6

- IC & TRANSISTORS -

7101	9965 000 13422	TEA5757H/V1
7111	5322 130 60159	BC846B
IC201	5322 209 15853	NJM4556AM
IC301	9965 000 14728	SPCA702A
IC302	9965 000 14729	E2PROM W27C020
IC303	9965 000 14730	SPCA711A
IC304	9965 000 14731	MSM514265C
IC401	9965 000 07260	IC TZA1024
IC402	9352 641 80557	SAA7324H/M2B
IC403	9965 000 14544	MM1469XH
IC404	5322 209 15853	NJM4556AM
IC501	9322 150 74668	IC SM TDA7468D (ST00) R
IC601	4822 209 16465	BA5417
IC701	4822 209 83824	NJM7805FA
IC801	9965 000 14732	CPU P87CS58SBBB
IC802	9965 000 04931	M24C01-WMN6
IC803	9965 000 14549	HT1621B
IC901	9965 000 14733	M65839FP
Q201	5322 130 60159	BC846B
Q208	5322 130 60159	BC846B
Q301	5322 130 60159	BC846B
Q401	4822 130 40981	BC337-25
Q402	4822 130 40981	BC337-25
Q404	5322 130 60159	BC846B
Q405	4822 130 41246	BC327-25
Q407	5322 130 60159	BC846B
Q501	4822 130 40981	BC337-25
Q502	4822 130 42804	BC817-25
Q503	4822 130 42804	BC817-25
Q504	4822 130 42804	BC817-25
Q505	4822 130 42804	BC817-25
Q510	5322 130 60159	BC846B
Q711	5322 130 60159	BC846B
Q712	5322 130 60159	BC846B
Q721	4822 130 60373	BC856B
Q722	5322 130 60159	BC846B
Q723	5322 130 60159	BC846B
Q726	5322 130 60159	BC846B
Q731	4822 130 40981	BC337-25
Q734	9965 000 04160	2SD1664R
Q735	5322 130 60159	BC846B
Q736	△9965 000 14734	TRANSISTOR 2SB1370E TP
Q737	5322 130 60159	BC846B
Q738	4822 130 60373	BC856B
Q739	4822 130 60373	BC856B

ELECTRICAL PARTS LIST

- IC & TRANSISTORS -

Q740	5322 130 60159	BC846B
Q820	5322 130 60159	BC846B
Q901	5322 130 60159	BC846B
Q903	5322 130 60159	BC846B
Q905	5322 130 60159	BC846B
Q920	5322 130 44593	BC369
Q921	5322 130 60159	BC846B
Q922	5322 130 60159	BC846B
RE801	9965 000 14545	SENSOR RECEIVER

Note: Only these parts mentioned in the list are normal service parts.